User's Guide

Publication number E3469-97004
July 2000

For Safety information, Warranties, and Regulatory information, see the pages behind the index.

© Copyright Agilent Technologies 1994-2000
All Rights Reserved

Hitachi SH7709A/29 Emulation

Hitachi SH7709A/29 Emulation—At a Glance

This manual describes how to set up several Agilent Technologies emulation products: an emulation probe, an emulation module, and an emulation migration.

These emulators provide a low-cost way to debug embedded software for Hitachi SH7709A/29 Series microprocessor. The emulator lets you use the target processor's built-in background debugging features, including run control and access to registers and memory. A high-level source debugger can use the emulator to debug code running on the target system.

You can connect the emulator to an analysis probe or you can connect it to a debug port on the target system through the provided target interface module (TIM). The emulator can be controlled by a debugger on a host computer.

Emulation Probe

The emulation probe is a stand-alone emulator.

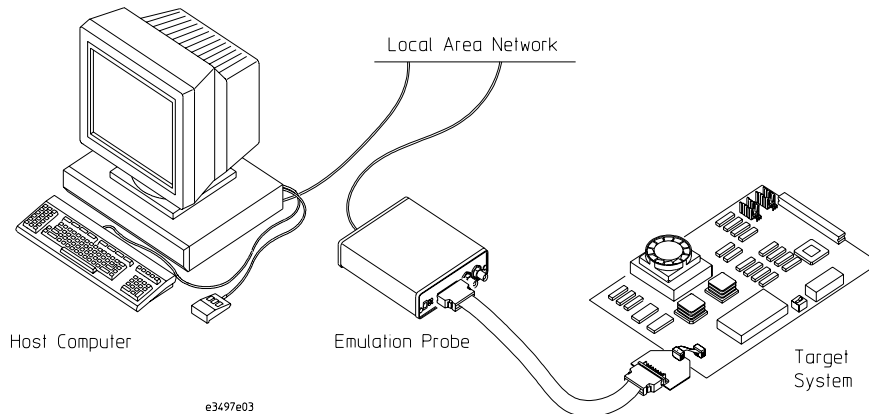

Emulation Module

The emulation module plugs into your Agilent Technologies 16600A/700A-series logic analysis system frame.

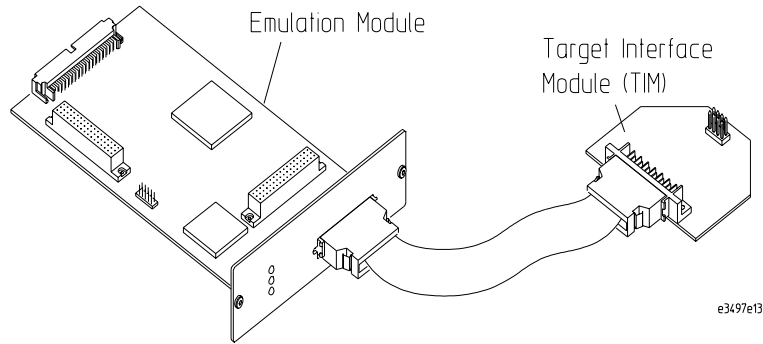

You can connect the emulation module to an analysis probe or you can connect it to a debug port on the target system through the provided target interface module (TIM).

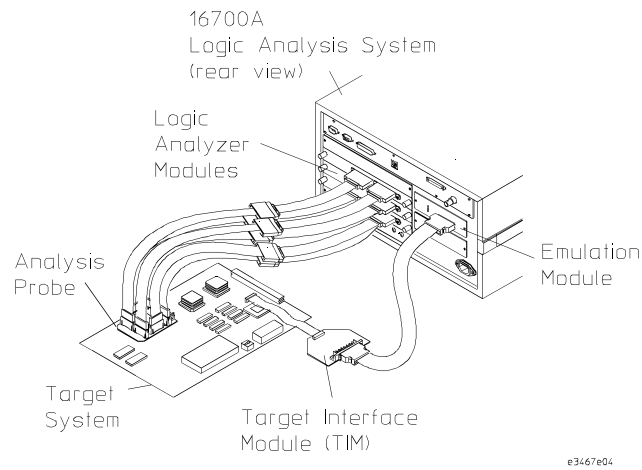

Emulation Migration

The emulation migration includes a target interface module and firmware. Use the emulation migration if you already have an emulation probe or an emulation module for another processor.

In This Book

This book documents the following products:

Emulation Probe		
Processors supported	Agilent Technologies Product ordered	Includes
SH7709A/29	E5900A Option #720	E3469A emulation probe, E3469A target interface module (TIM)

Emulation Module		
Processors supported	Agilent Technologies Product ordered	Includes
SH7709A/29	E5901A Option #720	16610A emulation module, E3469A target interface module (TIM)

Emulation Migration		
Processors supported	Agilent Technologies Product ordered	Includes
SH7709A/29	E5902A Option #720	E3469A target interface module (TIM)

Contents

1 Overview 11

Setup Flowchart 13

Emulation Probe 14

- Equipment supplied 14
- Minimum equipment required 16
- To connect the emulation probe to a power source 16
- Emulation probe connection sequence 18

Emulation Module 19

- Equipment supplied 19
- Minimum equipment required 20

Emulation Migration 21

- Equipment supplied 21
- Minimum equipment required 22

Additional Information Sources 23

2 Connecting the Emulation Probe to a LAN 25

Setting Up a LAN Connection to a PC or Workstation 27

- To obtain an IP address 28
- To configure LAN parameters using the built-in terminal interface 29
- To configure LAN parameters using BOOTP 32
- To set the 10BASE-T configuration switches 34
- To verify LAN communications 35

Setting Up a Serial Connection 36

- To set the serial configuration switches 37
- To connect a serial cable 37
- To verify serial communications 39

3 Installing the Emulation Module 41

- To install the emulation module in a 16700A-series logic analysis system or a 16701A expansion frame 43
- To install the emulation module in a 16600A-series logic analysis system 45

4 Installing Software on a 16600A/700A 47

- To list software packages which are installed (16600A/700A) 49
- To install the software from CD-ROM (16600A/700A) 50

5 Connecting the Emulator 51

Using the Emulation Control Interface 53

- To start the Emulation Control Interface from the main System window (emulation

- module) 54
- To start the Emulation Control Interface from the Workspace window (emulation module) 55
- To start the Emulation Control Interface from the Workspace window (emulation probe) 55

Designing a Target System 56

- Wiring the N-wire 56

Connecting the Emulator to the Target System 61

- To connect to a target system using a debug port 62
- To connect to a target system using an analysis probe 63
- Configuring the Emulator 64
- To configure using the Emulation Control Interface 65

Testing the emulator and target system 66

- To test memory accesses 66
- To test with a running program 66

6 Updating Firmware 67

Emulation Probe Firmware 69

- To display current firmware version information 69
- To update firmware for an emulation probe 69
- If there is a power failure during a firmware update 69

Emulation Module Firmware 70

- To display current firmware version information 70
- To update firmware for an emulation module using the Emulation Control Interface 70
- To update firmware for an emulation module using the Setup Assistant 71

7 Specifications and Characteristics 73

- Processor Compatibility 74
- Emulation Probe Electrical Characteristics 75
- Emulation Probe and Emulation Module Electrical Characteristics 76
- Emulation Probe Environmental Characteristics 77
- Emulation Module Environmental Characteristics 77

8 Troubleshooting the Emulator 79

- Troubleshooting Guide 81
- Status Lights 82
- Emulator Built-in Commands 85
 - To telnet to the emulator 85
 - To use the built-in commands 86
- Problems with the LAN Interface (Emulation Probe Only) 88
 - If you cannot verify LAN communication 88
 - If you have LAN connection problems 89
 - If the "POL" LED is lit 90
 - If it takes a long time to connect to the network 90
- Problems with the Serial Interface (Emulation Probe Only) 91
 - If you cannot verify RS-232 communication 91
 - If you have RS-232 connection problems with the MS Windows Terminal program 91
- Problems with the Target System 93
 - What to check first 93

To interpret the initial prompt 95

Problems with the LAN Interface 97

- If LAN communication does not work 97
- If it takes a long time to connect to the network 98

Problems with the Emulation Probe 99

- To run the power up self test 99
- To execute the built-in performance verification test (emulation probe only) 101

Problems with the Emulation Module 106

- To run the built-in performance verification test using the logic analysis system (emulation module only) 106
- To run complete performance verification tests using a telnet connection 107

Problem with the TIM 109

- To perform the TIM only PV tests with an emulation probe/module 109

Returning Parts to Agilent Technologies for Service 111

- To return a part to Agilent Technologies 111
- To obtain replacement parts 112

Cleaning the Instrument 113

Overview

Overview

This chapter describes:

- Equipment used with the emulation probe
- Connection sequences for the emulation probe
- Equipment used with the emulation module
- Additional information sources

Setup Flowchart

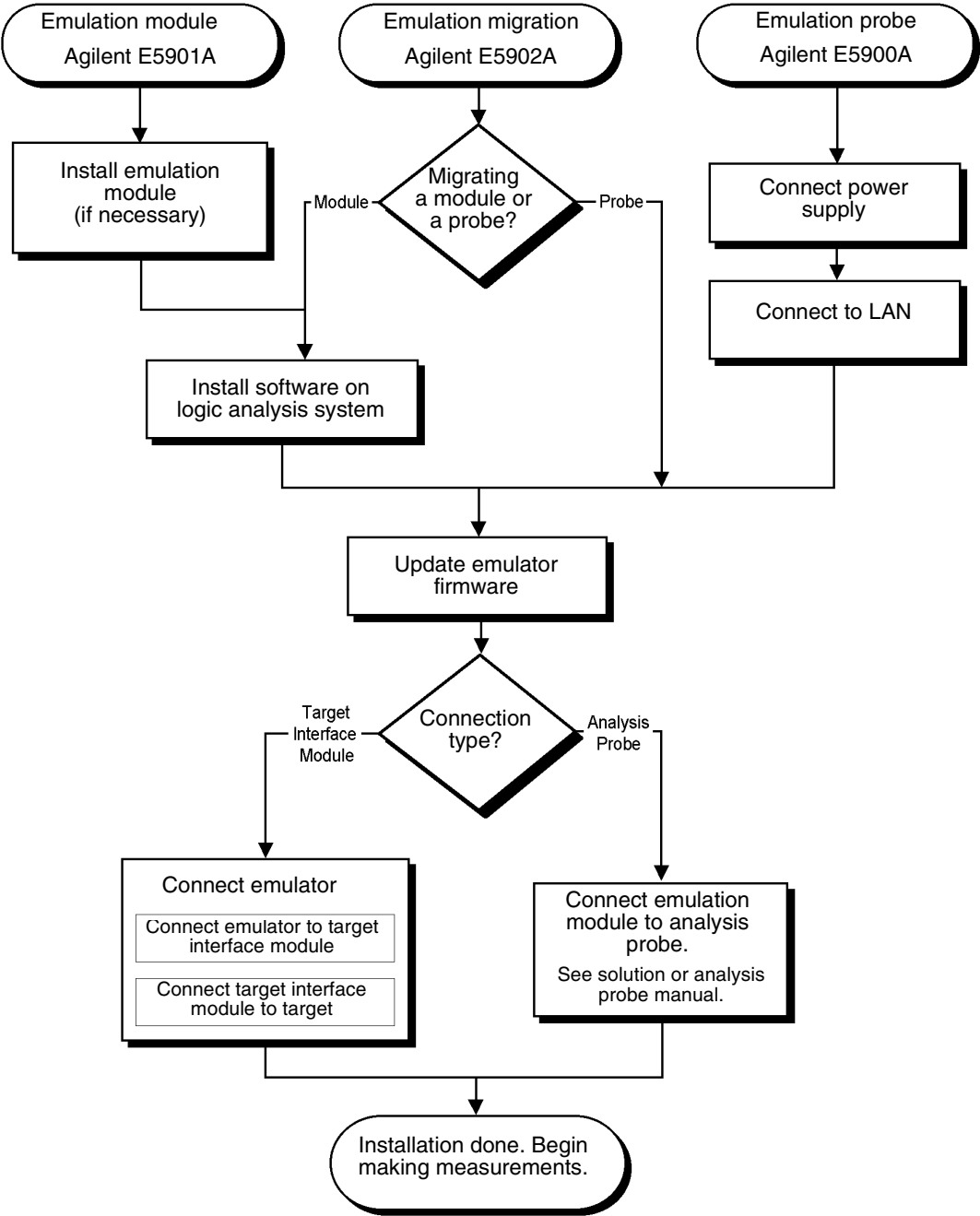

Emulation Probe

This section lists equipment supplied with the emulation probe and equipment requirements for using the emulation probe.

Equipment supplied

The equipment supplied with the emulation probe is shown in the illustration on the next page. It is listed below:

- An emulation probe.
- A 12V power supply for the emulation probe.
- A power cord.
- A target interface module (TIM) circuit board.
- A emulation module loopback test board (Agilent part number E3496-66502).
- A 50-pin ribbon cable for connecting the emulation module to the target interface module.
- A 14-pin ribbon cable for connecting the target interface module to the target system.
- A 30-pin ribbon cable for connecting the target interface module to the target system.
- A 36-pin ribbon cable for connecting the target interface module to the target system.
- This User's Guide.

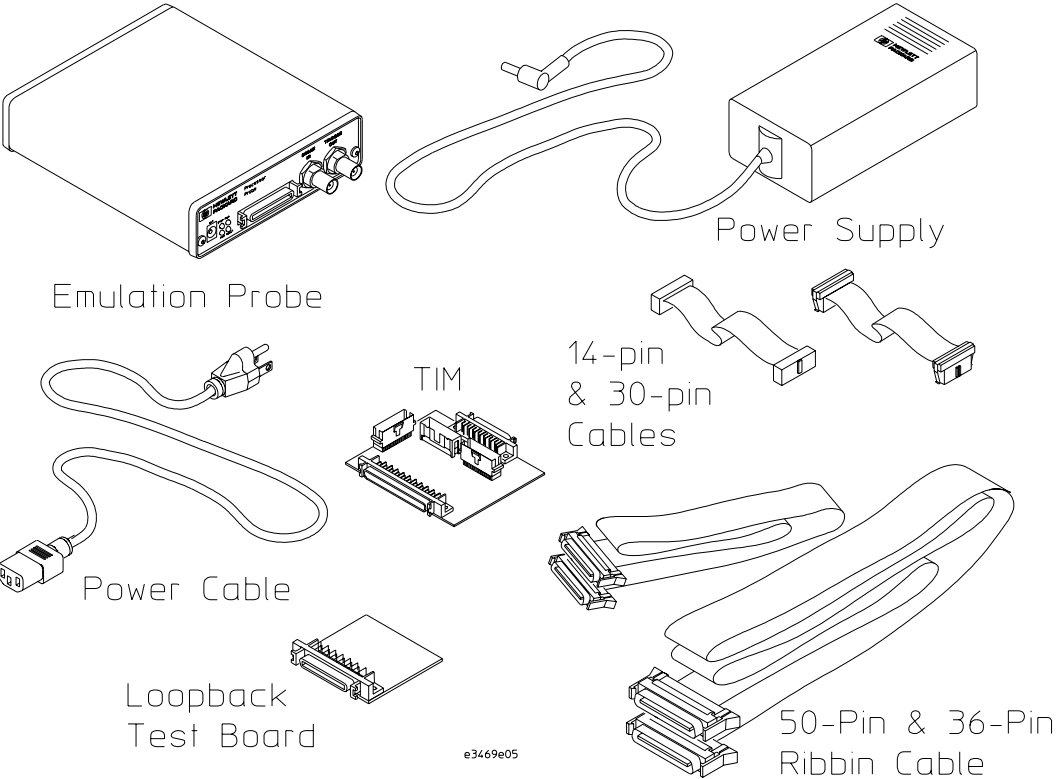

Equipment Supplied with Emulation Probe

Minimum equipment required

The following equipment is required to use the emulation probe:

- A method for connecting to the target system. The Agilent Technologies E8022A analysis probe provides a debug port connector. You can also design a debug port connector on the target system.
- A host computer, such as a PC or workstation.
- A LAN (local area network) to connect the emulation probe to the host computer.
- A user interface on the host computer, such as B3759A #720 Emulation Solution Interface or 3rd party's high-level source debugger.

To connect the emulation probe to a power source

The emulation probe does not have an On/Off switch. To turn the emulation probe on or off, plug or unplug it from the power supply.

The emulation probe is shipped from the factory with a power supply and cord appropriate for your country. If the cord you received is not appropriate for your electrical power outlet type, contact your Agilent Technologies sales and service office.

Warning

Use only the supplied Agilent Technologies power supply and cord.
Failure to use the proper power supply could result in electric shock.

Caution

Use only the supplied Agilent Technologies power supply and cord.
Failure to use the proper power supply could result in equipment damage.

1 Connect the power cord to the power supply and to a socket outlet.

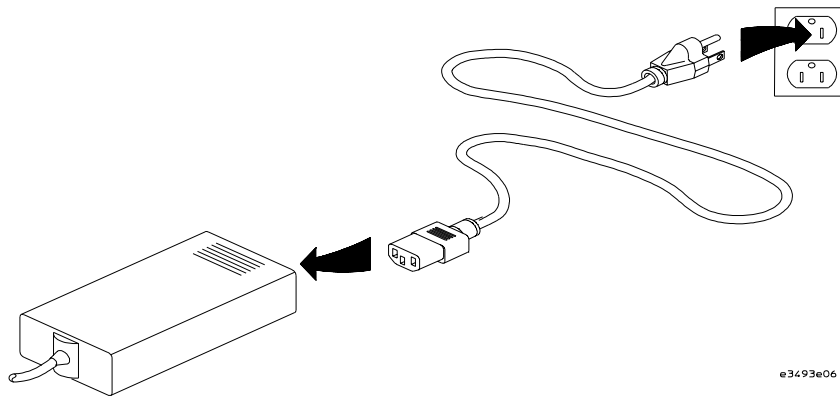

2 Connect the 12V power cord to the back of the emulation probe.

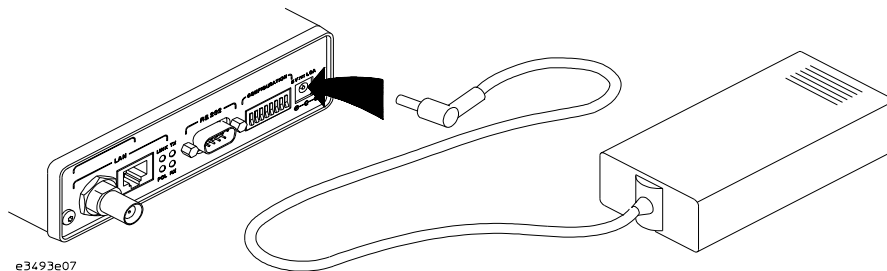

The power light on the target side of the emulation probe will light. The emulation probe does not have an On/Off switch.

With all components connected, power on your system in the following order:

- 1 Logic analyzer, if you are using one.
- 2 Emulation probe.
- 3 Your target system.

Power off your system in the following order:

- 1 Your target system
- 2 Emulation probe.
- 3 Logic analyzer, if you are using one.

Emulation probe connection sequence

Disconnect power from the target system, emulation probe, and logic analyzer before you make or break connections.

- 1 Connect the emulation probe to a LAN (page 25).
- 2 Connect the emulation probe to your target system (page 61).

Emulation Module

This section lists equipment supplied with the emulation module and lists the minimum equipment required to use the emulation module.

Equipment supplied

The equipment supplied with your emulation module includes:

- An Agilent Technologies 16610A emulation module. If you ordered an emulation module as part of your Agilent Technologies 16600A or 16700A logic analysis system, it is already installed in the frame.
- A target interface module (TIM) circuit board.
- A emulation module loopback test board (Agilent part number E3496-66502).
- Firmware for the emulation module on a CD-ROM.
- A 50-pin ribbon cable for connecting the emulation module to the target interface module.
- A 14-pin ribbon cable for connecting the target interface module to the target system.
- A 30-pin ribbon cable for connecting the target interface module to the target system.
- A 36-pin ribbon cable for connecting the target interface module to the target system.
- One Torx T-8, one Torx T-10, and one Torx T-15 screwdriver (if the emulation module was not installed at the factory).
- This User's Guide.

Chapter 1: Overview Emulation Module

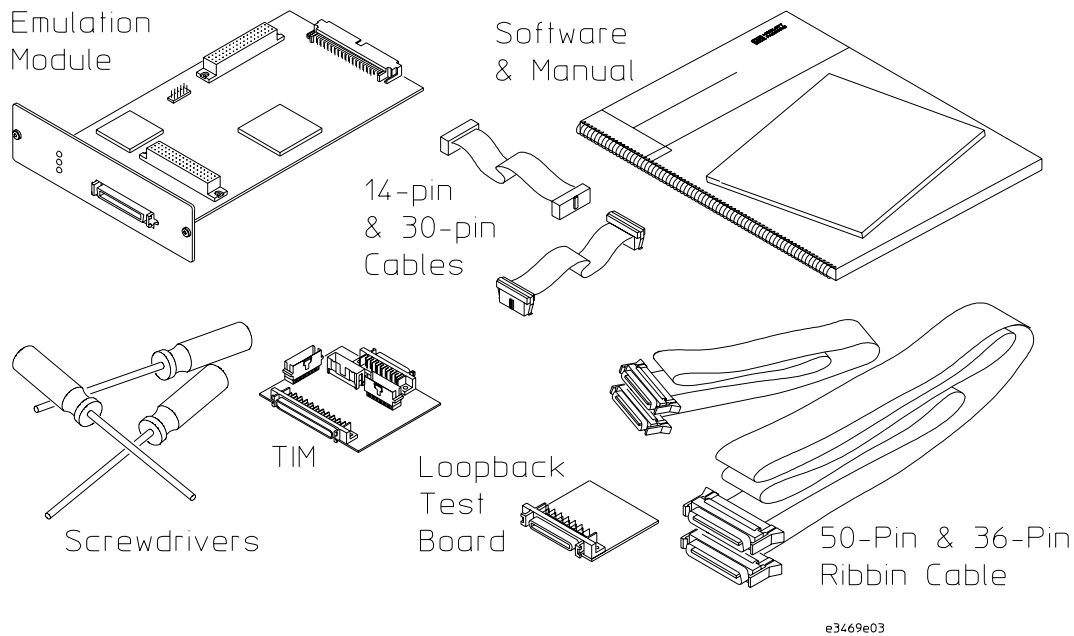

Equipment Supplied with the Agilent Technologies E5901A Emulation Module

Minimum equipment required

The following equipment is required to use the emulation module:

- A method for connecting to the target system. The Agilent Technologies E8022A analysis probe provides a debug port connector. You can also design a debug port connector on the target system.
- An Agilent Technologies 16600A or 16700A logic analysis system.
- A user interface on the host computer, such as B3759A #720 Emulation Solution Interface or 3rd party's high-level source debugger .

Emulation Migration

This section lists equipment supplied with the emulation migration and lists the minimum equipment required to use the emulation migration.

Equipment supplied

The equipment supplied with your emulation migration includes:

- A target interface module (TIM) circuit board.
- Firmware for the emulation module on a flexible disk.
- A 14-pin ribbon cable for connecting the target interface module to the target system.
- A 30-pin ribbon cable for connecting the target interface module to the target system.
- A 36-pin ribbon cable for connecting the target interface module to the target system.
- This User's Guide.

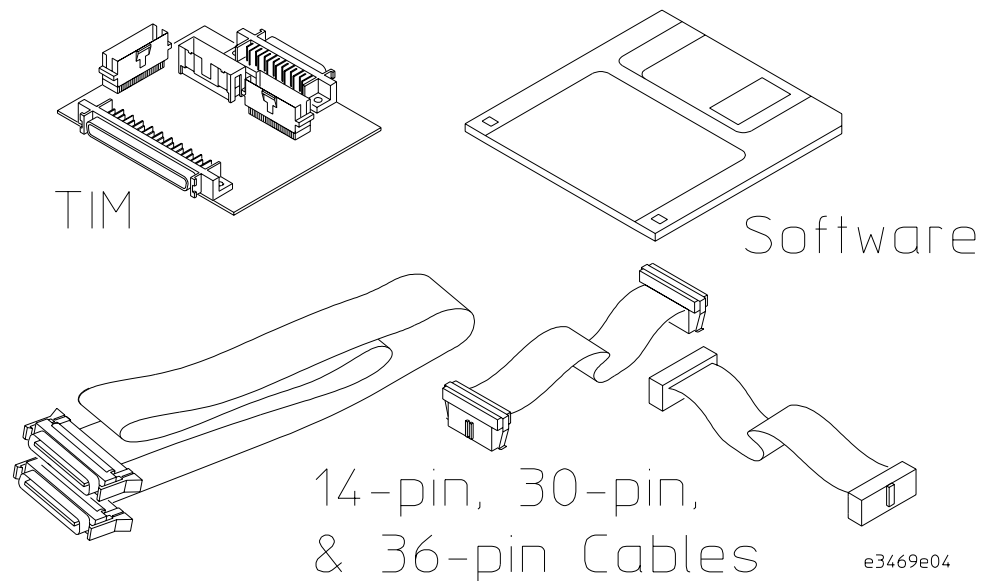

Minimum equipment required

The following equipment is required to use the emulation migration:

- An emulation module or emulation probe.
- A 50-pin data cable (supplied with the emulation module or probe).
- A method for connecting to the target system. The Agilent Technologies E8022A analysis probe provides a debug port connector. You can also design a debug port connector on the target system.
- A host computer such as a PC, a workstation, or an Agilent Technologies 16600A or 16700A logic analysis system.
- A user interface on the host computer, such as B3759A #720 Emulation Solution Interface or 3rd party's high-level source debugger .

Additional Information Sources

Additional or updated information can be found in the following places:

Newer editions of this manual may be available. Contact your local Agilent Technologies representative.

If you have an analysis probe, the instructions for connecting the probe to your target microprocessor are in the analysis probe documentation. The *Solutions for the Hitachi SH7709A/29 User's Guide* provides information on using the analysis probe and emulation module together.

Application notes may be available from your local Agilent Technologies representative or on the World Wide Web at:

<http://www.agilent.com/find/logicanalyzer>

The **measurement examples** include valuable tips for making emulation and analysis measurements. You can find the measurement examples under the system help in your Agilent Technologies 16600A/700A logic analysis system.

Chapter 1: Overview
Additional Information Sources

Connecting the Emulation Probe to a LAN

Connecting the Emulation Probe to a LAN

You can connect your PC or workstation to the emulation probe via a serial or LAN connection.

Serial connection

A serial connection allows you to complete all of the performance verification tests. Other use of the serial port is not supported: performance over a serial connection, especially if you are downloading code, may be unacceptably slow.

LAN connection

A LAN connection will allow you to make your measurements quickly and easily. A few of the performance verification tests cannot be run over a LAN.

Recommended connection

Use a LAN connection for routine use, and a serial connection for LAN configuration and for troubleshooting.

Setting Up a LAN Connection to a PC or Workstation

The emulation probe has two LAN connectors:

- A BNC connector that can be directly connected to a IEEE 802.3 Type 10BASE2 cable (ThinLAN). When using this connector, the emulation probe provides the functional equivalent of a Medium Attachment Unit (MAU) for ThinLAN.
- An IEEE 802.3 Type 10BASE-T (StarLAN) connector.

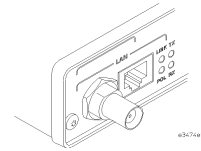

Use either the 10BASE2 or the 10BASE-T connector. Do *not* use both. The emulation probe will not work with both connected at the same time.

You must assign an IP address (Internet address) to the emulation probe before it can operate on the LAN. You can also set other network parameters such as a gateway address. The IP address and other network parameters are stored in nonvolatile memory within the emulation probe.

The emulation probe automatically sets a subnet mask based on the subnet mask used by other devices on the network.

You can configure LAN parameters in any of the following ways:

- Using the built-in terminal interface over a serial connection. This is the most reliable method.
- Using BOOTP. BOOTP is part of the HP-UX, SunOS, and Solaris operating systems.

To obtain an IP address

- 1 Obtain the following information from your local network administrator or system administrator:

- An IP address for the emulation probe.

You can also use a "LAN name" for the emulation probe, but you must configure it using the integer dot notation (such as 127.0.0.1).

- The gateway address.

The gateway address is an IP address and is entered in integer dot notation. The default gateway address is 0.0.0.0, which allows all connections on the local network or subnet. If connections are to be made to workstations on other networks or subnets, this address must be set to the address of the gateway machine.

- 2 Find out whether port numbers 6470 and 6471 are already in use on your network.

The host computer interfaces communicate with the emulation probe through two TCP service ports. The default base port number is 6470. The second port has the next higher number (default 6471).

The default numbers (6470, 6471) can be changed if they conflict with some other product on your network.

To change the port numbers, see page 29. If you have already set the IP address, you can use a **telnet** connection instead of a serial connection to connect to the processor probe.

- 3 Write down the link-level address of the processor probe.

You will need this address if you use BOOTP to set the IP address.

The link-level address (LLA) is printed on a label above the LAN connectors on the emulation probe. This address is configured in each processor probe shipped from the factory and cannot be changed.

IP Address of Processor probe
LAN Name of Processor Probe
Gateway Address
Link-Level Address of Processor Probe

To configure LAN parameters using the built-in terminal interface

- 1 Set configuration switches S1 through S4 to CLOSED, and set the other switches as appropriate for your serial interface.

Switch settings are printed on the bottom of the emulation probe. If you will use a baud rate of 9600 baud, set the switches like this:

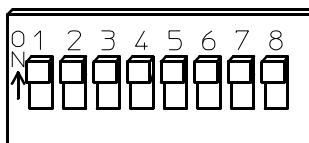

e3490b05

- 2 Connect an ASCII terminal (or terminal emulator) to the emulation probe's RS-232 port with a 9-pin RS-232 cable.
Complete instructions for setting up a serial connection begin on page 36.
- 3 Plug in the emulation probe's power cord. Press the terminal's <RETURN> key a couple times. You should see a prompt such as "p>", "?>", or "c>".
At this point, you are communicating with the emulation probe's built-in terminal interface.
- 4 Display the current LAN configuration values by entering the **lan** command:

```
R>lan
lan is disabled
lan -i 0.0.0.0
lan -g 0.0.0.0
lan -p 6470
Ethernet Address : 08000903212f
```

The "lan -i" line shows the current IP address (IP address) of the emulation probe.

The Ethernet address, also known as the link level address, is preassigned at the factory, and is printed on a label above the LAN connectors.

- 5 Enter the following command:

```
lan -i <internet> [-g <gateway>] [-p <port>]
```

The **lan** command parameters are:

-i <internet> The IP address which you obtained from your network administrator.

Chapter 2: Connecting the Emulation Probe to a LAN
Setting Up a LAN Connection to a PC or Workstation

-g <gateway> The gateway address. Setting the gateway address allows access outside your local network or subnet.

-p <port> This changes the base TCP service port number.
The default numbers (6470, 6471) can be changed if they conflict with some other product on your network. TCP service port numbers must be greater than 1024. If you change the base port, the new value must also be entered in the /etc/services file on the host computer. For example, you could modify the line:

```
hp64700    6470/tcp
```

The IP address and any other LAN parameters you change are stored in nonvolatile memory and will take effect the next time the processor probe is powered off and back on again.

- 6 Disconnect the power cord from the emulation probe, and connect the emulation probe to your network.

This connection can be made by using either the 10BASE-T connector or the 10BASE2 (BNC) connector on the emulation probe. Do not use both connectors at the same time.

- 7 Set the configuration switches to indicate the type of connection that is to be made.

Switch S1 must be set to OPEN, indicating that a LAN connection is being made.

Switch S5 should be CLOSED if you are connecting to the BNC connector:

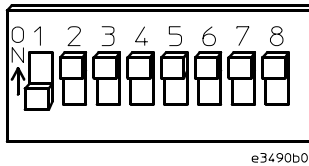

Switch S5 should be OPEN if you are connecting to the 10BASE-T connector:

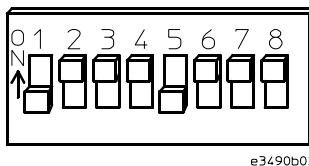

Set all other switches to CLOSED.

- 8 Connect the power cord to the emulation probe.

- 9 Verify your emulation probe is now active and on the network. See "To verify LAN communications" on page 35.

Once you have set a valid IP address, you can use the **telnet** utility to connect to the emulation probe, and use the **lan** command to change LAN parameters.

Example

To assign an IP address of 192.6.94.2 to the emulation probe, enter the following command:

```
R>lan -i 192.6.94.2
```

Now, cycle power on the emulation probe so that the new address will take effect.

See Also

"Solving Problems," page 79, if you have problems verifying LAN communication.

To configure LAN parameters using BOOTP

Use this method only on a workstation which is running **bootpd**, the BOOTP daemon.

1 Make sure that BOOTP is enabled on your host computer.

If the following commands yield the results shown below, the BOOTP protocol is enabled:

```
$ grep bootp /etc/services
bootps      67/udp
bootpc      68/udp
$ grep bootp /etc/inetd.conf
bootps dgram udp wait    root  /etc/bootpd  bootpd
```

If the commands did not yield the results shown, you must either add BOOTP support to your workstation or use a different method to configure the emulation probe LAN parameters.

2 Add an entry to the host BOOTP database file, `/etc/bootptab`. For example:

```
# Global template for options common to all Agilent Technologies
64700
# emulators and Processor Probes.
# Use a different gateway addresses if necessary.
hp64700.global:\
    :gw=0.0.0.0:\
    :vm=auto:\
    :hn:\
    :bs=auto:\
    :ht=ether

# Specific emulator entry specifying hardware address
# (link-level address) and ip address.
hprobe.div.hp.com:\
    :tc=hp64700.global:\
    :ha=080009090B0E:\
    :ip=192.6.29.31
```

In this example, the "ha=080009090B0E" identifies the link-level address of the emulation probe. The "ip=192.6.29.31" specifies the IP address that is assigned to the emulation probe. The node name is "hprobe.div.hp.com".

3 Connect the emulation probe to your network.

This connection can be made by using either LAN connector on the processor probe.

- 4 Set the configuration switches to indicate the type of connection that is to be made.

Switch S1 must be set to OPEN, indicating that a LAN connection is being made.

Switch S6 must be set to OPEN to enable BOOTP mode.

Switch S5 should be set to CLOSED if you are connecting to the BNC connector

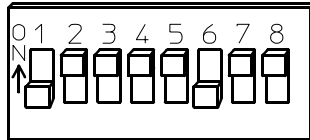

e3490b03

Switch S5 should be set to OPEN if you are connecting to the 10BASE-T connector.

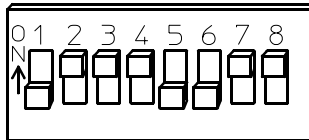

e3490b04

Set all other switches to CLOSED.

- 5 Connect the power cord to the emulation probe.
Verify that the power light stays on after 10 seconds.
The IP address will be stored in EEPROM.
- 6 Set switch S6 back to CLOSED.
Do this so that the emulation probe does not request its IP address each time power is cycled. The IP address is stored in EEPROM, so BOOTP does not need to be run again. Leaving this switch on will result in slower performance, increased LAN traffic, and even failure to power up (if the BOOTP server becomes inactive).
- 7 Verify your emulation probe is now active and on the network. See "To verify LAN communications" on page 35.

See Also

For additional information about using bootpd, refer to the bootpd (1M) man page.

To set the 10BASE-T configuration switches

Set switches S7 and S8 to CLOSED unless one of the following conditions is true:

- If the LAN cable exceeds the standard length, set switch S7 to OPEN.
The emulation probe has a switch-selectable, twisted-pair receiver threshold. With switch S7 set to OPEN, the twisted-pair receiver threshold is lowered by 4.5 dB. This should allow you to use cable lengths of up to about 200 meters. If you use a long cable, you should consult with your LAN cabling installer to ensure that:
 - The device at the other end of the cable has long cable capability, and
 - The cable is high-grade, low-crosstalk cable with crosstalk attenuation of greater than 27.5 dB.

When switch S7 is set to CLOSED, the LAN port operates at standard 10BASE-T levels. A maximum of 100 meters of UTP cable can be used.

- If your network doesn't support Link Beat integrity checking or if the emulation probe is connected to a non 10BASE-T network (such as StarLAN) set this switch to LINK BEAT OFF (0 or OPEN).

In normal mode (switch S8 set to CLOSED), a link integrity pulse is transmitted every 15 milliseconds in the absence of transmitted data. It expects to receive a similar pulse from the remote MAU. This is the standard link integrity test for 10BASE-T networks. If your network doesn't support the Link Beat integrity checking or if the Software Probe is used on a non 10BASE-T network (such as StarLAN) set this switch to LINK BEAT OFF (OPEN).

Note

Setting switch S8 to OPEN when Link Beat integrity checking is required by your network will cause the remote MAU to disable communications.

To verify LAN communications

- 1 Verify your emulation probe is now active and on the network by issuing a **telnet** to the IP address.

This connection will give you access to the emulation probe's built-in terminal interface.

- 2 To view the LAN parameters, enter the **lan** command at the terminal interface prompt.
- 3 To exit from this telnet session, type <CTRL>D at the prompt.

The best way to change the emulation probe's IP address, once it has already been set, is to telnet to the emulation probe and use the terminal interface **lan** command to make the change. Remember, after making your changes, you must cycle power or enter a terminal interface **init -p** command before the changes take effect. Doing this will break the connection and end the telnet session.

If You Have Problems

If you encounter problems, refer to the "Problems" chapter (page 79).

Example

```
$ telnet 192.35.12.6

R>lan
lan is enabled
lan -i 192.35.12.6
lan -g 0.0.0.0
lan -p 6470
Ethernet Address : 0800F090B30
```

Setting Up a Serial Connection

To set up a serial connection, you will need to:

- Set the serial configuration switches
- Connect a serial cable between the host computer and the emulation probe
- Verify communications

Serial connections on a workstation

If you are using a UNIX workstation as the host computer, you need to use a serial device file. If a serial device file does not already exist on your host, you need to create one. Once it exists, you need to ensure that it has the appropriate permissions so that you can access it. See the system documentation for your workstation for help with setting up a serial device.

Serial connections on a PC

Serial connections are supported on PCs. You must use hardware handshaking if you will use the serial connection for anything other than setting LAN parameters.

If you are using a PC as the host computer, you do not need to set up any special files.

To set the serial configuration switches

- 1 Set switch S1 to CLOSED (RS-232).
- 2 Set switches S2-S4 to CLOSED.
- 3 Set switch S5 to CLOSED (HW HANDSHAKE ON) if your serial interface uses the DSR:CTS/RTS lines for flow control. Set S5 to OPEN (HW HANDSHAKE OFF) if your serial interface uses software flow control (XON/XOFF).

If your serial interface supports hardware handshaking, you should use it (set switch S5 to CLOSED). Hardware handshaking will make the serial connection much more reliable.

- 4 Set switches S6-S8 for the baud rate you will use. These switch settings are listed on the bottom of the emulation probe.

The higher baud rates may not work reliably with all hosts and user interfaces. Make sure the baud rate you choose is supported by your host and user interface.

Example

To use a baud rate of 9600 baud, set the switches as follows:

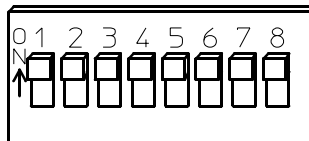

e3490b05

To connect a serial cable

CAUTION

Use a grounded, shielded cable. If the cable is not shielded, or if the cable is not grounded at the serial controller, the emulation probe may be damaged by electrostatic discharge.

Connect an RS-232C modem cable from the host computer to the processor probe. The recommended cable is HP part number C2932A. This is a 9-pin cable with one-to-one pin connections.

Chapter 2: Connecting the Emulation Probe to a LAN
Setting Up a Serial Connection

If you want to build your own RS-232 cable, follow the pinout shown in the following figure:

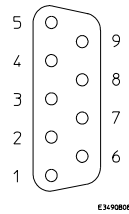

Serial Cable Pinout

Pin Number	Signal	Signal Description
1	DCD	Data Carrier Detect (not used)
2	TD	Transmit Data (data coming from Agilent Technologies emulation probe)
3	RD	Receive Data (data going to Agilent Technologies emulation probe)
4	DTR	Data Terminal Ready (not used)
5	GND	Signal Ground
6	DSR	Data Set Ready (Output from Agilent Technologies emulation probe)
7	RTS	Request to Send (Input to Agilent Technologies emulation probe)
8	CTS	Clear to Send (connected to pin 6)
9	RING	Ring Indicator (not used)

To verify serial communications

- 1 Start a terminal emulator program on the host computer.
If you are using a PC, the Terminal application in Microsoft Windows will work fine.
If you are using a UNIX workstation, you can use a terminal emulator such as **cu** or **kermit**.
- 2 Plug the power cord into the emulation probe.
When the emulation probe powers up, it sends a message (similar to the one that follows) to the serial port and then displays a prompt:

```
Copyright (c) Agilent Technologies 1987  
All Rights Reserved.  Reproduction, adaptation, or translation without prior  
written permission is prohibited, except as allowed under copyright laws.
```

```
E3499A Series Emulation System  
Version:  A.07.06 06May97  
Location:  Generics
```

```
E3469A Hitachi SH7709A/29 Emulator  
Version:  A.01.00
```

R>

The version numbers may be different for your emulation probe.

- 3 Press the Return or Enter key a few times.
You should see a prompt such as "p>", "C>", or "?>".
For information about the commands you can use, enter ? or help at the prompt.

See Also "Problems with the Serial Interface," page 91.

Chapter 2: Connecting the Emulation Probe to a LAN
Setting Up a Serial Connection

Installing the Emulation Module

Installing the Emulation Module

This chapter shows you how to install an emulation module in your Agilent Technologies 16600A/700A-series logic analysis system.

If your emulation module is already installed in your logic analysis system frame, you may skip this chapter.

CAUTION

These instructions are for trained service personnel. To avoid dangerous electric shock, do not perform any service unless qualified to do so. Do not attempt internal service or adjustment unless another person, capable of rendering first aid and resuscitation, is present.

Electrostatic discharge can damage electronic components. Use grounded wriststraps and mats when you handle modules.

To install the emulation module in a 16700A-series logic analysis system or a 16701A expansion frame

You will need T-10 and T-15 Torx screw drivers.

- 1 Turn off the logic analysis system and **REMOVE THE POWER CORD**. Remove any other cables (such as probes, mouse, or video monitor).
- 2 Turn the logic analysis system frame upside-down.
- 3 Remove the bottom cover.

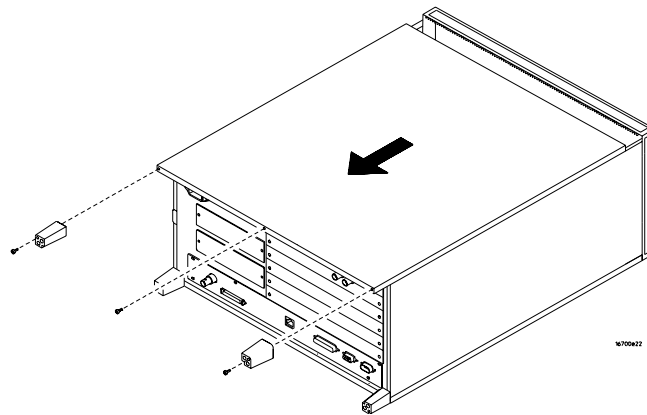

- 4 Remove the slot cover.
You may use either slot.

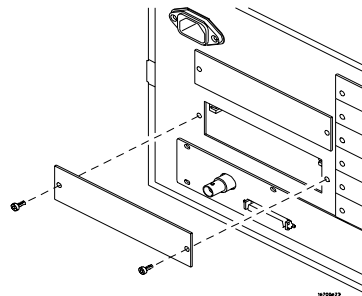

5 Install the emulation module.

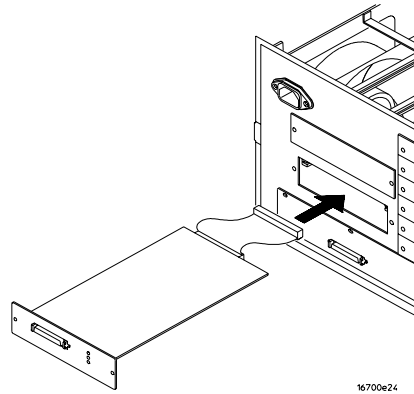

6 Connect the cable and re-install the screws.

You may connect the cable to either of the two connectors. If you have two emulation modules, note that many debuggers will work only with the "first" module: the one toward the top of the frame ("Slot 1"), plugged into the connector nearest the back of the frame.

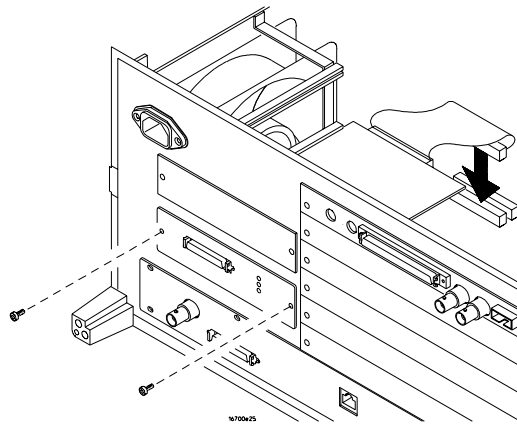

7 Reinstall the bottom cover, then turn the frame right-side-up.

8 Plug in the power cord, reconnect the other cables, and turn on the logic analysis system.

The new emulation module will be shown in the system window.

See Also

See page 67 for information on giving the emulation module a "personality" for your target processor.

To install the emulation module in a 16600A-series logic analysis system

You will need T-8, T-10, and T-15 Torx screw drivers.

- 1 Turn off the logic analysis system and **REMOVE THE POWER CORD**. Remove any other cables (such as probes, mouse, or video monitor).
- 2 Slide the cover back.

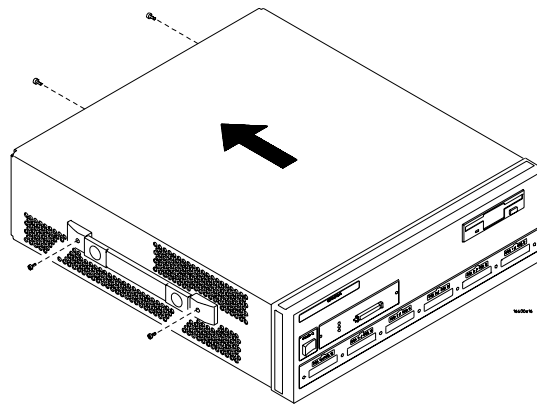

- 3 Remove the slot cover.

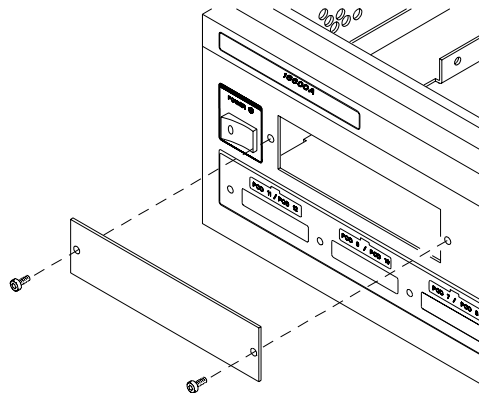

Chapter 3: Installing the Emulation Module
Installing the Emulation Module

- 4 Install the emulation module.
- 5 Connect the cable and re-install the screws.

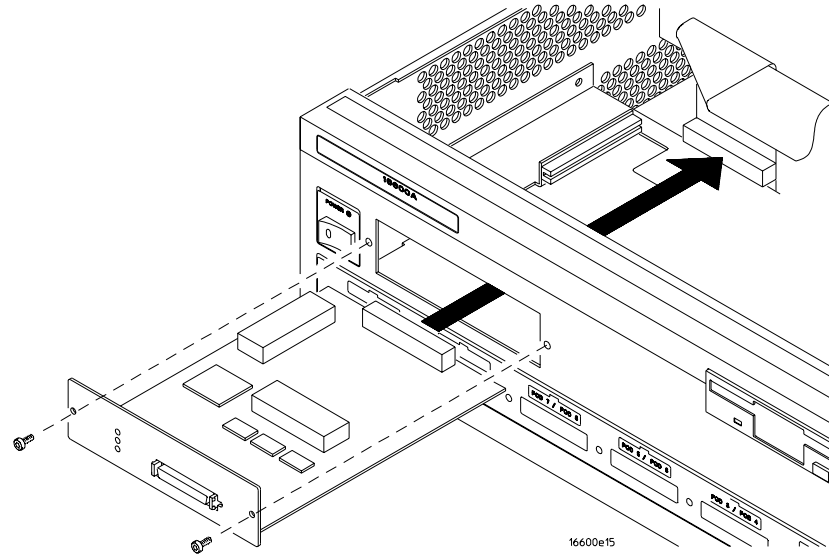

- 6 Reinstall the cover.
Tighten the screws snugly (2 N•m or 18 inch-pounds).
- 7 Plug in the power cord, reconnect the other cables, and turn on the logic analysis system.
The new emulation module will be shown in the system window.

See Also

See page 67 for information on giving the emulation module a "personality" for your target processor.

Installing Software on a 16600A/700A

Installing Software on a 16600A/700A

This chapter explains how to install the software you will need for your analysis probe or emulation solution.

Installing and loading

Installing the software will copy the files to the hard disk of your logic analysis system. Later, you will need to **load** some of the files into the appropriate hardware module.

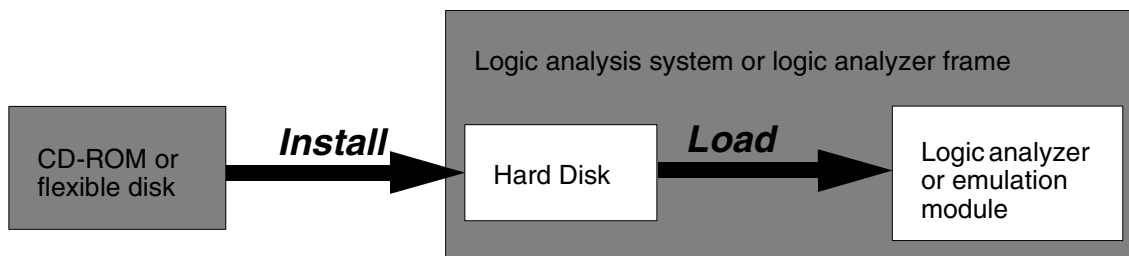

What needs to be installed

Agilent Technologies 16600A/700A-series logic analysis systems

If you ordered an emulation solution with your logic analysis system, the software was installed at the factory.

The following files are installed when you install a processor support package from the CD-ROM:

- Logic analysis system configuration files
- Personality files for the Setup Assistant
- Emulation module firmware

To list software packages which are installed (16600A/700A)

- In the System Administration Tools window, click **List...** .

To install the software from CD-ROM (16600A/700A)

Installing a processor support package from a CD-ROM will take just a few minutes. If the processor support package requires an update to the Agilent Technologies 16600A/700A operating system, installation may take approximately 15 minutes. If the CD-ROM drive is not connected, see the instructions printed on the CD-ROM package.

- 1 Turn on the CD-ROM drive first and then turn on the logic analysis system.
- 2 Insert the CD-ROM in the drive.
- 3 Click the **System Admin** icon.
- 4 Click **Install...** .
Change the media type to "CD-ROM" if necessary.
- 5 Click **Apply**.
- 6 From the list of types of packages, select "PROC-SUPPORT."
A list of the processor support packages on the CD-ROM will be displayed.
- 7 Click on the "SH3" package.
If you are unsure if this is the correct package, click Details for information on what the package contains.
- 8 Click **Install...** .
The dialog box will display "Progress: completed successfully" when the installation is complete.
- 9 Click **Close**.

The configuration files are stored in `/hplogic/configs/hp/processor`.

See Also

The instructions printed on the CD-ROM package for a summary of the installation instructions.
The online help for more information on installing, licensing, and removing software.

Connecting the Emulator

Connecting the Emulator

This chapter shows you how to connect the emulator to the target system and how to configure the emulator and target processor.

Overview

Here is a summary of the steps for connecting and configuring the emulator:

- 1 Make sure the target system is designed to work properly with the emulator. (Page 56.)
- 2 Install the emulation module in your logic analysis system, if necessary. (Page 41.)
If you are connecting an emulation module to an Agilent Technologies 16600A/700A-series logic analysis system, use the Setup Assistant to guide you through steps 3-4.
- 3 Connect the emulator to your target system using the 50-pin cable and the TIM (Page 61)
- 4 Update the firmware of the emulator, if necessary. (Page 67.)
- 5 Verify communication between the emulator and the target.
- 6 Configure the emulator

Using the Emulation Control Interface

The Emulation Control Interface in your Agilent Technologies 16600A/700A-Series logic analysis system allows you to control an emulator (an emulation module or an emulation probe).

As you set up the emulator, you will use the Emulation Control Interface to:

- Update firmware (which preloads or changes the processor-specific personality of the emulator).
- Change the LAN port assignment (rarely necessary).
- Run performance verification tests on the emulator.

The Emulation Control Interface allows you to:

- Run, break, reset, and step the target processor.
- Set and clear breakpoints.
- Read and write registers.
- Read and write memory.
- Read and write I/O memory.
- Read and write the emulator configuration.
- Download programs (in Motorola S-Record or Intel Hex format) to the target system RAM or ROM.
- View emulator status and errors.
- Write and play back emulator command script files.

If you have an emulation probe, this interface also allows you to configure the LAN address of the emulation probe.

Using a debugger with the Emulation Control Interface is not recommended because:

- The interface can get out of synchronization when commands are issued from both interfaces. This causes windows to be out-of-date and can cause confusion.
- Most debuggers cannot tolerate another interface issuing commands and may not start properly if another interface is running.

See Also

All of the Emulation Control Interface windows provide online help with a Help button or a Help->On this window menu selection. Refer to the online help for complete details about how to use a particular window.

To start the Emulation Control Interface from the main System window (emulation module)

- 1 In the System window, click the emulation module icon.
- 2 Select **Start Session...**

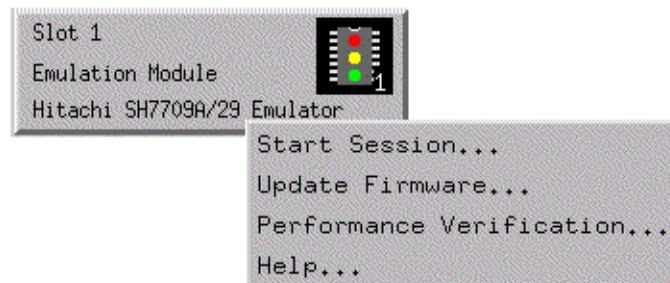

To start the Emulation Control Interface from the Workspace window (emulation module)

- 1 Open the Workspace window.
- 2 Drag the Emulator icon onto the workspace.
- 3 Right-click the Emulator icon, and then select **Start Session...**

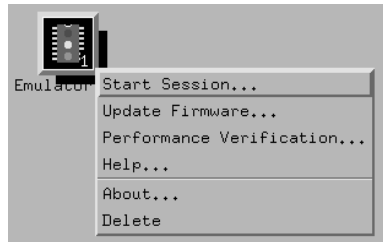

To start the Emulation Control Interface from the Workspace window (emulation probe)

If you have a stand-alone emulation probe connected to the logic analysis system via LAN, use the Emulation Probe icon instead of the Emulation Module icon.

- 1 Open the Workspace window.
- 2 Drag the Emulation Probe icon onto the workspace.
- 3 Right-click the Emulation Probe icon, and select **Start Session...**

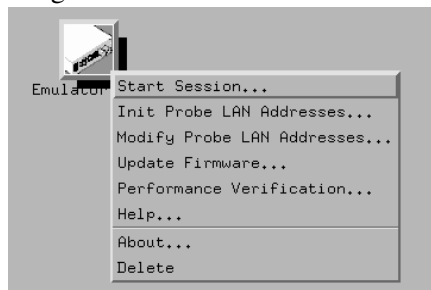

- 4 In the Session window, enter the IP address or LAN name of the emulation probe, then click **Start Session**.

Designing a Target System

This section will help you design a target system that will work with the Agilent Technologies E3469A Emulation Probe.

Wiring the N-wire

To connect the Agilent Technologies E3469A Emulation Probe to your target system, you have to prepare 14, 30 or 36-pin signals called N-wire on your target system using the appropriate connector. Agilent Technologies recommends 30-pin connector on your target system. You must use either 30 or 36-pin connector on your target system in order to use the real-time trace feature of the SH7709A/29 with the Agilent Technologies emulation probe. (You also need the Agilent Technologies E5903A #720 Trace Port Analyzer for the real-time trace.)

N-wire (For using 3M 14-pin connector)

Cable Pin Number	Signal	SH7709A/29 Pin Number QFP
1	TCK	88
3	/TRST	60
5	TDO	87
7	ASEBRK/BRKACK	86
9	TMS	85
11	TDI	84
13	/RESET	83
8	I/O V _{DD} (3.3V)	
Even Pins (Except for pin 8)	V _{SS}	

Pin assignments for 14-pin connector is the following.

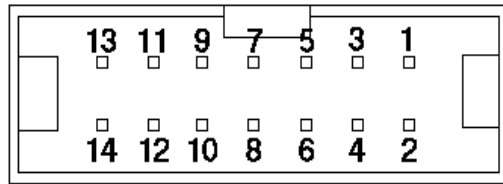

14-pin connector

You can use following connectors.

Supplier	Product Number	Description
Sumitomo3M (Japan)	7614-6002	Low profile straight header connector
3M (U.S.A)	2514-6002UB	Low profile straight header connector

N-wire (For using AMP 30-pin connector)

Cable Pin Number	Signal	SH7709A/29 Pin	Cable Pin Number	Signal	SH7709A/29 Pin
1	/RESETP	193	16	GND	-
2	GND	-	17	TDI	138
3	AUDCK	151	18	GND	-
4	GND	-	19	TMS	137
5	AUDATA0	135	20	GND	-
6	GND	-	21	TDO	120
7	AUDATA1	133	22	GND	-
8	GND	-	23	TRST	136
9	AUDATA2	131	24	ASEMD0	127
10	GND	-	25	GND	-
11	AUDATA3	130	26	ASEBRKAK	128
12	GND	-	27	/RST0	-
13	AUDSYNC	94	28	GND	-
14	GND	-	29	VccQ(3.3v)	-
15	TCK	139	30	TRG	-

Pin assignments for the 30-pin connector is the following.

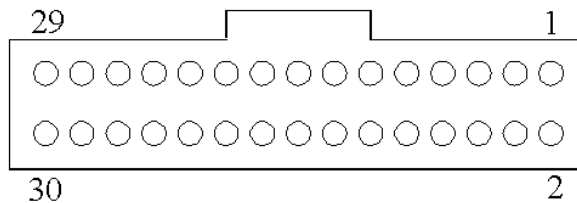

30-pin connector

You can use following connectors.

Supplier	Product Number	Description
AMP	104068-3	Header Assembly, Vertical
AMP	104069-5	Header Assembly, Right Angle

N-wire (For using Hirose 36-pin connector)

Cable Pin Number	Signal	SH7709A/29 Pin	Cable Pin Number	Signal	SH7709A/29 Pin
1	NC	-	19	TMS	137
2	GND	-	20	GND	-
3	AUDATA0	135	21	/TRST	136
4	GND	-	22	GND	-
5	AUDATA1	133	23	TDI	138
6	GND	-	24	GND	-
7	AUDATA2	131	25	TDO	120
8	GND	-	26	GND	-
9	AUDATA3	130	27	/ASEBRKAK	128
10	GND	-	28	GND	-
11	/AUDSYNC	94	29	Vdd	-
12	GND	-	30	GND	-
13	NC	-	31	/RESET	193
14	GND	-	32	GND	-
15	NC	-	33	GND	-
16	GND	-	34	GND	-
17	TCK	139	35	AUDCK	151
18	GND	-	36	GND	-

Pin assignments for the 36-pin connector is the following.

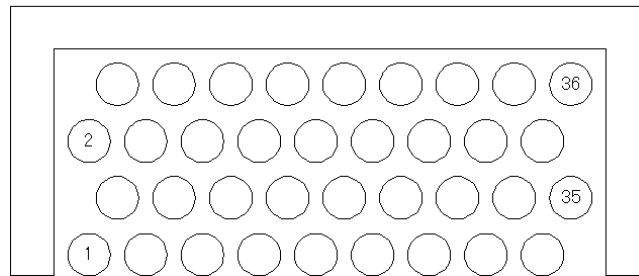
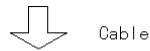

TopView

36-pin connector

You can use following connectors.

Supplier	Product Number	Description
Hirose	DX10M-36S DX10M-36SE DX10GM-36SE	One touch lock receptacle, right angle

Caution

Locate the connector within 10cm (4 inches) from the microprocessor on your target system. If the connector is located further than 10cm (4 inches) away from the microprocessor, Agilent Technologies E3469A Emulation Probe may not work correctly.

Target V_{DD}

The Agilent Technologies E3469A Emulation Probe may draw up to 10 mA from target V_{DD} .

Connecting the Emulator to the Target System

Choose one of the following methods for connecting the emulator to a target system.

- Directly through a debug port connector on the target board.
- Through an Agilent Technologies E8022A analysis probe, which provides a direct connection to the debug port pins.

After you have connected the emulator to your target system, you may need to update the firmware in the emulator.

CAUTION



- Turn off the target system and disconnect it from all power sources when connecting the emulator to your target system.
- Electrostatic discharge can damage electronic components. Use grounded wriststraps and mats when you handle the target interface module.

See Also

For information on designing a debug port on your target board, see page 56.
For a list of the parts supplied with the emulator, see page 19.

To connect to a target system using a debug port

The emulator can be connected to a target system through a debug port. The emulator should be connected to a 14, 30, or 36-pin connector on the target system using the cable assembly provided. (Choose only one cable appropriate for your target system.)

- 1 Turn off the target system and disconnect it from all power sources.
- 2 Plug one end of the 50-pin cable into the emulator.

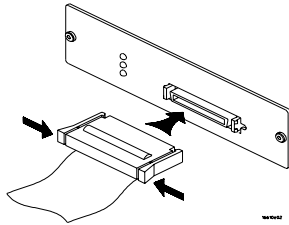

- 3 Plug the other end of the 50-pin cable into the target interface module.
- 4 Plug one end of the 14, 30, or 36-pin cable into the target interface module.
- 5 Plug the other end of the 14, 30, or 36-pin cable into the debug port on the target system.

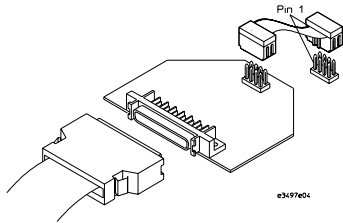

- 6 Turn on the power to the logic analysis system or the emulation probe and then the target system.

CAUTION



Be careful to orient the connector as it appears on the target interface module. If the connector is rotated, your target system or the emulator may be damaged.

See Also

"Designing a Target System" (page 56) for information on designing a target system for use with the emulator.

To connect to a target system using an analysis probe

- 1 Remove power from the target system.
- 2 Plug one end of the 50-pin cable into the emulator.
- 3 Plug the other end of the 50-pin cable into the target interface module.
- 4 Plug one end of the 30-pin cable into the target interface module.
- 5 Plug the other end of the 30-pin cable into the debug port on the Analysis Probe.

Configuring the Emulator

The emulator has several user-configurable options. These options may be customized for specific target systems and saved in configuration files for future use.

The easiest way to configure the emulator is through the Emulation Control Interface in an Agilent Technologies 16600A or 16700A logic analysis system.

If you use the Emulation Control Interface, please refer to the online help in the Configuration window for information on each of the configuration options.

You may also use the emulator configuration window of your debugger (B3759A #720) to configure your emulator.

To configure using the Emulation Control Interface

The easiest way to configure the emulators is to use the Emulation Control Interface.

1 Start an Emulation Control Interface session.

From an emulation module:

- In the system window, click the Emulation Control Interface icon, and then select “Start Session...”.

For an emulation probe:

- In the workspace window, drag the emulation probe icon onto the workspace, and then select “Start Session...”.

2 Open a Configuration window.

Select “Configuration...” from the Emulation Control Interface icon or from the Navigate menu in any Emulation Control Interface window.

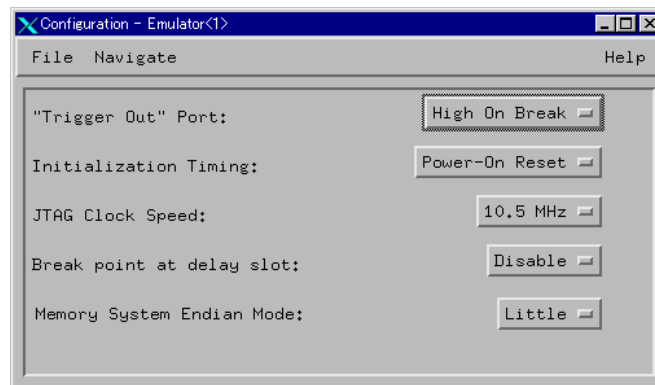

3 Set the configuration options, as needed.

The configuration selections will take effect when you close the configuration window or when you move the mouse pointer outside the window.

4 Save the configuration settings.

To save the configuration settings, open the File Manager window and click **Save....**

See Also

Help->**Help on this window** in the Configuration window for information on each of the configuration options.

Help in the Emulation Control Interface menu for help on starting an Emulation Control session.

Testing the emulator and target system

After you have connected and configured the emulator, you should perform some simple tests to verify that everything is working.

See Also

“Troubleshooting the Emulator” on page <Reference> for information on testing the emulator hardware.

To test memory accesses

- 1 Start the Emulation Control Interface and configure the emulator, if necessary.
 - 2 Open the Memory window.
 - 3 Write individual locations or fill blocks of memory with patterns of your choosing.
The access size is the size of memory access that will be used to write or read the memory values.
 - 4 Use the Memory I/O window to stimulate I/O locations by reading and writing individual memory locations.
-

To test with a running program

To more fully test your target, you can load simple programs and execute them.

- 1 Compile or assemble a small program and store it in a Motorola S-Record or Intel Hex file.
 - 2 Use the Load Executable window to download the program into RAM or flash memory.
 - 3 Use the Breakpoints window to set breakpoints. Use the Registers window to initialize register values.
The new register or breakpoint values are sent to the processor when you press the Enter key or when you move the cursor out of the selected register field.
 - 4 In the Run Control window, click Run.
 - 5 Use the Memory Mnemonic window to view the program and use the Memory window to view any output which has been written to memory.
-

Updating Firmware

Updating Firmware

Firmware gives your emulator a “personality” for a particular processor or processor family.

After you have connected the emulator to your target system, you may need to update the firmware to give it the right personality for your processor.

You must update the firmware if:

- You have an emulation module which was not shipped already installed in the logic analysis system.
- You need to change the personality of the emulator for a new processor.
- You have an updated version of the firmware from Agilent Technologies.

The procedure for updating firmware for an emulation probe is different from the procedure for updating firmware for an emulation module.

Emulation Probe Firmware

To display current firmware version information

- Use telnet or a terminal emulator to access the built-in "terminal interface" and use the ver command to view the version information for firmware currently in the emulation probe.
-

To update firmware for an emulation probe

To update the firmware, you must have access to the World Wide Web and a PC or a workstation connected to your emulation probe.

- 1 Download the new firmware from the following World Wide Web site:
<http://www.cos.agilent.com/probe>
- 2 Follow the instructions on the web site for installing the firmware.

If Agilent Technologies sends you firmware on a floppy disk, install the firmware from the floppy disk. The README file on the floppy disk contains instructions for installing the firmware using a PC or workstation.

If there is a power failure during a firmware update

If there is a power glitch during a firmware update, some bits may be lost during the download process, possibly resulting in an Agilent Technologies processor probe that will not boot up.

- Set switch S4 to OPEN, then cycle power. This tells the Agilent Technologies processor probe to ignore everything in the Flash EPROM except the boot code.
 - Repeat the firmware update process.
 - Set switch S4 to CLOSED, then cycle power. This restores the Agilent Technologies processor probe to its normal mode.
-

Emulation Module Firmware

Always update firmware by installing a processor support package. This will ensure that the version of the Emulation Control Interface software is compatible the version of the emulator firmware.

To display current firmware version information

- 1 In the Update Firmware window, click Display Current Version.
There are usually two firmware version numbers: one for “Generics” and one for the personality of your processor.
-

To update firmware for an emulation module using the Emulation Control Interface

- 1 End any run control sessions which may be running.
- 2 In the Workspace window, remove any Emulator icons from the workspace.
- 3 Install the processor support package from the CD-ROM, if necessary.
- 4 In the system window, click the emulation module and select **Update Firmware...**

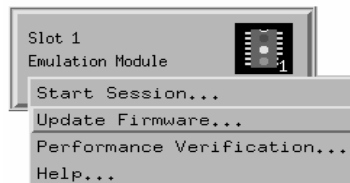

To update firmware for an emulation module using the Setup Assistant

- 5 In the Update Firmware window, select the firmware to load into the emulation module.
- 6 Click **Update Firmware**.
In about 20 seconds, the firmware will be installed and the screen will update to show the current firmware version.

See Also

“Installing Software” beginning on page 48 for instructions on how to install the processor support package from the CD-ROM.

To update firmware for an emulation module using the Setup Assistant

The Setup Assistant is an online tool for connecting and configuring your logic analysis system for microprocessor and bus analysis. The Setup Assistant is available on the Agilent Technologies 16600A and 16700A-series logic analysis systems.

This menu-driven tool will guide you through the connection procedures for connecting the logic analyzer to an analysis probe, an emulation module, or other supported equipment. It will also guide you through connecting an analysis probe to the target system.

Do not use the Setup Assistant to connect an emulation probe if you already have an emulation module installed.

- 1 Install the processor support package from the CD-ROM.
- 2 Start the Setup Assistant by clicking its icon in the system window.

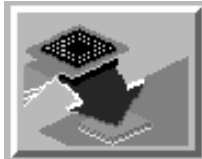

- 3 Follow the instructions displayed by the Setup Assistant.

See Also

Page 48 for instructions on how to install a the processor support package from the CD-ROM.

Chapter 6: Updating Firmware
To update firmware for an emulation module using the Setup Assistant

Specifications and Characteristics

The following operating characteristics are not specifications, but are typical operating characteristics for the Agilent Technologies 16610A emulation module, emulation probe, and SH7709A/29 Target interface module.

Processor Compatibility

The Agilent Technologies E3469A emulator supports the SH7709A/29 microprocessors.

Emulation Probe Electrical Characteristics

BNC, labeled TRIGGER OUT

Output Drive

Logic high level with 50-ohm load ≥ 2.0 V. Logic low level with 50-ohm load ≤ 0.4 V. Output function is selectable by the Agilent Technologies 16600A/700A Logic Analysis system. Refer to Online Help for more information.

BNC, labeled BREAK IN

Input

Edge-triggered TTL level input (active high), 20 pf, with 2K ohms to ground in parallel. Maximum input: 5 V above V_{CC} ; 5 V below ground. Input function is selectable by the Agilent Technologies 16600A/700A Logic Analysis system. Refer to Online Help for more information. The BNC introduces approximately 2.5 ms skid after break-in at 25 MHz.

Communications

Serial Port

9-pin female type “D” subminiature connector. RS-232 DCE to 115.2 kbaud.

10BASE-T LAN Port

RJ-45 connector. IEEE 802.3 10BASE-T (StarLAN).

10BASE 2 LAN Port

50-ohm BNC connector. IEEE 802.3 10BASE2 (ThinLAN). When using this connector, the emulation probe provides the functional equivalent of a Medium Attachment Unit (MAU) for ThinLAN.

Accessory Power Out

12 V, 3.0A, center negative

Power Supply

Input

100-240 V, 1.0 A, 50/60 Hz, IEC 320 connector.

Output

12 V, 3.3 A

Emulation Probe and Emulation Module Electrical Characteristics

Maximum Ratings

Characteristics for the SH7709A/29 Microprocessor	Notes	Symbol	Min	Max	Unit
Input voltage range		V_{in}	-0.5	5.5	V

Emulation Probe Environmental Characteristics

Temperature

Operating, 0 to +40 °C (+32 to +104 °F); nonoperating, -40 to +60 °C (-40 to +140 °F).

Altitude

Operating/nonoperating 4600 m (15 000 ft).

Relative Humidity

15% to 95%.

For indoor use only.

Emulation Module Environmental Characteristics

The Agilent Technologies 16610A emulation module meets the environmental characteristics of the logic analysis system in which it is installed.

For indoor use only.

Chapter 7: Specifications and Characteristics
Emulation Module Environmental Characteristics

Troubleshooting the Emulator

Troubleshooting the Emulator

If you have problems with the emulation module, your first task is to determine the source of the problem. Problems may originate in any of the following places:

- The connection between the emulation module and your debugger
- The emulation module itself
- The connection between the target interface module and the target system
- The target system

You can use several means to determine the source of the problem:

- The troubleshooting guide on the next page
- The status lights on the emulation probe or emulation module
- The emulator "performance verification" tests
- The emulator's built-in "terminal interface" commands

Troubleshooting Guide

Common problems and what to do about them

Symptom	What to do	See also
Commands from debugger have no effect	Your debugger may not be configured properly. If this does not work, continue with the steps for the next symptom....	page 85
Emulator built-in commands do not work	<p>1 Run the emulator performance verification tests.</p> <p>2 If the performance verification tests pass, then there is an electrical problem with the connection to the target processor OR the target system may not have been designed according to "Designing a Target System."</p>	page 101 page 56, page 93
"Slow or missing clock" message after a logic analyzer run	Check that the target system is running user code or is in reset. (This message can appear if the processor is in background mode.)	
Host computer reports LAN connection problems	Follow the checklist in the "If you have LAN problems" section.	page 97
Commands from the Run Control tool or debugger have no effect	Verify LAN communication.	page 35

Status Lights

Emulation Module Status Lights

The emulation module uses status lights to communicate various modes and error conditions.

The following table gives more information about the meaning of the power and target status lights.

○ = LED is off

● = LED is on

* = Not applicable (LED is off or on)

Power/Target Status Lights

Pwr/Target LEDs	Meaning
<input type="radio"/> Reset <input type="radio"/> Break <input type="radio"/> Run	No target system power, or emulation module is not connected to the target system
<input checked="" type="radio"/> Reset <input type="radio"/> Break <input type="radio"/> Run	Target system is in a reset state
<input type="radio"/> Reset <input checked="" type="radio"/> Break <input type="radio"/> Run	The target processor is executing in Debug Mode
<input type="radio"/> Reset <input type="radio"/> Break <input checked="" type="radio"/> Run	The target processor is executing user code
<input type="radio"/> Reset <input checked="" type="radio"/> Break <input checked="" type="radio"/> Run	Only boot firmware is good (other firmware has been corrupted)

Emulation Probe Status lights

The following illustration shows the status lights on both sides of the emulation probe and what they mean:

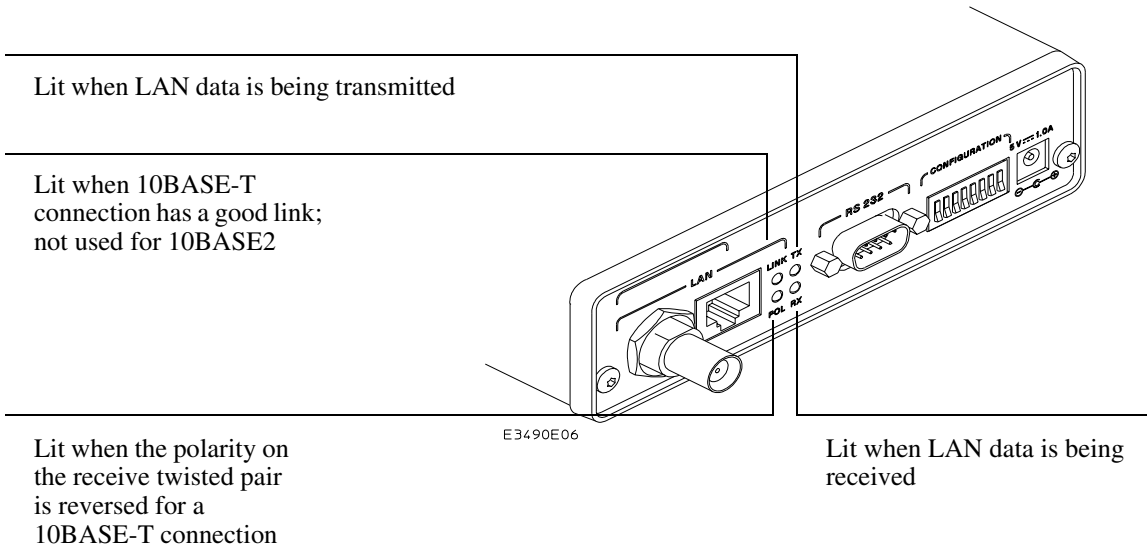
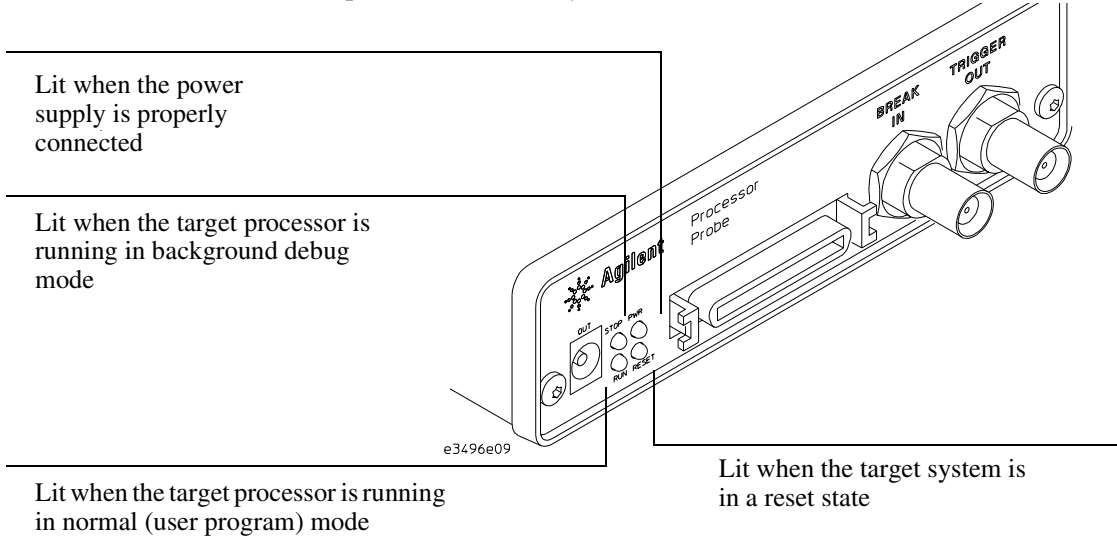

The emulation probe communicates various modes and error conditions via the status lights. The meanings of the status lights are shown on the previous page.

The following table gives more information about the meaning of the power and target status lights.

- = LED is off
- = LED is on
- * = Not applicable (LED is off or on)

Power/Target Status Lights

Pwr/Target LEDs	Meaning
○○ ○○	emulation probe is not connected to power supply
○● ○○	No target system power, or emulation probe is not connected to the target system
○● ○●	Target system is in a reset state
●● ●○	Only boot firmware is good (other firmware has been corrupted)
●● ○○	The target processor is executing in Debug Mode
○● ●○	The target processor is executing user code

Emulator Built-in Commands

The emulator has some built-in "terminal interface" commands which you can use for troubleshooting. You can access the terminal interface using:

- A telnet (LAN) connection
- A "debugger command" window in your debugger
- A serial connection (see page 36)

To telnet to the emulator

You can establish a telnet connection to the emulator if:

- A host computer and the logic analysis system are both connected to a local-area network (LAN), and
- The host computer has the telnet program (often part of the operating system or an internet software package).

To establish a telnet connection:

1 Find out the port number of the emulator.

The default port number of the first emulation module in an Agilent Technologies 16600A/700A series logic analysis system is 6472. The default port of a second module in an Agilent Technologies 16600A-series system is 6476. The default port numbers of a third and fourth module in an expansion frame are 6480 and 6484. These port numbers can be changed, but that is rarely necessary.

2 Find out the LAN address or LAN name of the logic analysis system.

3 Start the telnet program.

If the LAN name of the logic analysis system is "test2" and you have only one emulation module installed, the command might look like this:

```
telnet test2 6472
```

4 If you do not see a prompt, press the <Return> key a few times.

To exit from this telnet session, type <CTRL>D at the prompt.

To use the built-in commands

Here are a few commonly used built-in commands:

Useful built-in commands

b	Break -- go into the background monitor state
cf	Configuration -- read or write configuration options
help	Help -- display online help for built-in commands
init	Initialize -- init -c re-initializes everything in the emulation module except for the LAN software; init -p is the equivalent of cycling power (it will break LAN connections)
lan	configure LAN address
m	Memory -- read or write memory
reg	Register -- read or write a register
r	Run -- start running user code
rep	Repeat -- repeat a command or group of commands
rst	Reset -- reset the target processor (the emulation module will wait for you to press the target's RESET button)
s	Step -- do a low-level single step
ver	Version -- display the product number and firmware version of the emulation module

The prompt indicates the status of the emulation module:

Emulation module prompts

U	Running user program
M	Running in background monitor
p	No target power
R	Emulation reset
r	Target reset
?	Unknown state

Examples

To set register R0, then view R0 to verify that it was set, enter:

```
R>rst -m
M>reg r0=ffff
M>reg r0
  reg R0=0000ffff
```

To break execution then step a single instruction, enter:

```
M>b  
M>s  
  PC=xxxxxxxx  
M>
```

To determine what firmware version is installed in the emulation module, enter:

```
M>ver
```

See Also

Use the `help` command for more information on these and other commands. Note that some of commands listed in the help screens are generic commands for Agilent Technologies emulators and may not be available for your product.

If you are writing your own debugger, contact Agilent Technologies for more information.

Problems with the LAN Interface (Emulation Probe Only)

If you cannot verify LAN communication

If you cannot verify connection using the procedure in "To verify LAN communication", or if the commands are not accepted by the emulation probe:

- Make sure that you have connected the emulation probe to the proper power source and that the power light is lit.
- Make sure that you wait for the power-on self test to complete before connecting.
- Make sure that the LAN cable is connected. Watch the LAN LED's to see whether the emulation probe is seeing LAN activity. Refer to your LAN documentation for testing connectivity.
- Make sure that only one of the LAN ports is connected.
- Make sure the emulation probe communication configuration switches are set correctly. Unplug the emulation probe power cord, then plug it in again to make sure the switch settings are read correctly by the emulation probe.
- Check that the Run Control Tool or debugger was configured with the correct LAN address. If the emulation probe is on a different subnet than the host computer, check that the gateway address is correct.
- Make sure that the emulation probe's IP address is set up correctly. Use the RS-232 port to verify this that the IP address is set up correctly. When you are connected to the RS-232 port, run performance verification on the emulation probe's LAN interface with the "pv" command.
- It's also possible for there to be a problem with the emulation probe firmware while the LAN interface is still up and running. In this case, you must reboot the emulation probe by disconnecting power to the emulation probe and reconnecting it again.
- Use a serial connection to run the LAN performance verification tests (see page 101).

If you have LAN connection problems

- ❑ If the emulation probe does not accept commands from the logic analysis system:
 1. Check that switch S1 is "0" (attached to LAN, not RS-232).
 2. Check that switch S5 is in the correct position for your LAN interface (either 10BASE2 or 10BASE-T).(Remember: if you change any switch settings, the changes do not take effect until you cycle power.)
- ❑ If the emulation probe still does not respond, you need to verify the IP address and gateway mask of the emulation probe. To do this, connect the emulation probe to a terminal or terminal emulator (see page 36), change the switch settings so it is connected to RS-232, and enter the "lan" command. The output looks something like this:

```
lan -i 15.5.24.116
lan -g 15.5.23.1
lan -p 6470
Ethernet Address : 08000909BAC1
```

"lan -i" shows the internet address is 15.5.24.116 in this case. If the Internet address (IP) is not what you expect, you can change it with the 'lan -i <new IP>' command.

"lan -g" shows the gateway address. Make sure it is the address of your gateway if you are connecting from another subnet, or 0.0.0.0 if you are connecting from the local subnet.

"lan -p" shows the port is 6470. If the port is not 6470, you must change it with the "lan -p 6470" command (unless you have deliberately set the port number to a different value because of a conflict).

If the "POL" LED is lit

The "POL" LED indicates that the polarity is reversed on the receive pair if you are using a 10BASE-T connection. The emulation probe should still work properly in this situation, but other LAN devices may not work.

If it takes a long time to connect to the network

- ❑ Check the subnet masks on the other LAN devices connected to your network. All of the devices should be configured to use the same subnet mask.

Subnet mask error messages do not indicate a major problem. You can continue using the emulation probe.

The emulation probe automatically sets its subnet mask based on the first subnet mask it detects on the network. If it then detects other subnet masks, it will generate error messages.

If there are many subnet masks in use on the local subnet, the emulation probe may take a very long time to connect to the network after it is turned on.

To "clean up" the network, connect a terminal to the emulation probe. You can then see error messages which will help you identify which devices on the network are using the wrong subnet masks.

Problems with the Serial Interface (Emulation Probe Only)

If you cannot verify RS-232 communication

If the emulation probe prompt does not appear in the terminal emulator window:

- Make sure that you have connected the emulation probe to the proper power source and that the power light is lit.
- Make sure that you have properly configured the data communications switches on the emulation probe and the data communications parameters on the host computer. You should also verify that you are using the correct cable.

The most common type of data communications configuration problem involves the configuration of the emulation probe as a DTE device instead of as a DCE device. If you are using the wrong type of cable, no prompt will be displayed.

A cable with one-to-one connections will work with a PC or an HP Series 700 workstation.

If you have RS-232 connection problems with the MS Windows Terminal program

- Remember that Windows 3.1 only allows two active RS-232 connections at a time. To be warned when you violate this restriction, choose Always Warn in the Device Contention group box under 386 Enhanced in the Control Panel.
- Use the "Terminal" program (usually found in the Accessories windows program group) and set up the "Communications..." settings as follows:

```
Baud Rate: 9600 (or whatever you have chosen for the emulator)
Data Bits: 8
Parity: None
Flow Control: hardware
Stop Bits: 1
```

When you are connected, hit the Enter key. You should get a prompt back. If nothing echos back, check the switch settings on the emulation probe.

Chapter 8: Troubleshooting the Emulator
Problems with the Serial Interface (Emulation Probe Only)

- ❑ If the switches are in the correct position and you still do not get a prompt when you hit return, try turning OFF the power to the emulation probe and turning it ON again.
- ❑ If you still don't get a prompt, make sure the RS-232 cable is connected to the correct port on your PC, and that the cable is appropriate for connecting the PC to a DCE device.

With certain RS-232 cards, connecting to an RS-232 port where the emulation probe is turned OFF (or is not connected) will hang the PC. The only way to get control back is to reboot the PC. Therefore, we recommend that you always turn ON the emulation probe before attempting to connect via RS-232.

Problems with the Target System

This section describes how to determine whether your target system is causing problems with the operation of the emulation module.

What to check first

- 1 Try some basic built-in commands using the Command Line window or a telnet connection:

```
U>rst  
R>
```

This should reset the target and display a "R>" prompt.

```
R>b  
M>
```

This should stop the target and display an "M>" prompt.

```
M>reg r1  
reg r1=00000000  
M>
```

This should read the value of the r1 register (the value will probably be different on your target system).

```
M>m 0..  
00000000 7c3043a6 7c2802a6 7c3143a6 4bf04111  
00000010 00000000 00000000 00000000 00000000  
00000020 00000000 00000000 00000000 00000000  
00000030 00000000 00000000 00000000 00000000  
00000040 00000000 00000000 00000000 00000000  
00000050 00000000 00000000 00000000 00000000  
00000060 00000000 00000000 00000000 00000000  
00000070 00000000 00000000 00000000 00000000  
M>
```

This should display memory values starting at address 0.

```
M>s
```

This should execute one instruction at the current program counter.

If any of these commands don't work, there may be a problem with the design of your target system, a problem with the revision of the emulation you are using, or a problem with the configuration of the emulation module. The following steps will help you identify the problem.

- 2 Check that the emulation module firmware matches your processor. To do this, enter:

```
M>>ver
```

See Also

Page 85 for information on entering built-in commands.

To interpret the initial prompt

The initial prompt can be used to diagnose several common problems. To get the most information from the prompt, follow this procedure:

Connect the emulation module/probe to your target system.

Make sure that your target system is turned off.

Set the default configuration settings. Enter:

```
M>init -c
```

If the response is "!ERROR 905! Driver firmware is incompatible with ID of attached device"

Make sure the target interface module is connected to the cable of the emulation module, then try the "init -c" command again.

When you enter the command, the prompt should be showing either "?>" or "p>".

Please follow the steps below.

- 1 If the prompt shows "?>", you must turn the target system's power off and turn it back on. When the target power is turned on, the prompt should show "R>".
- 2 If the prompt shows "p>", you must turn the target system's power on. When the target power is turned on, the prompt should show "R>".
- 3 If the prompt still shows either "p>" or "?>" after executing the above steps, check the voltage of the V_{DD} of the Hitachi-UDI debug port. The voltage should be same as the target V_{DD} (normally 3.0V).
- 4 When you see the "R>" prompt, enter the following command:

```
R>b
```

The prompt should show "M>". If the prompt does not change to "M>", check the processor's /TRST signal. The signal should be driven to high for the proper operation.

- 5 If the prompt does not show "M>" after executing the above step, check the Hitachi-UDI clock speed. The speed should be slower than the processor's internal module clock speed. You may change the clock speed by entering the following command.

```
R>cf speed=CLOCK(1-7)
```

You must choose the CLOCK speed from the following

Chapter 8: Troubleshooting the Emulator
Problems with the Target System

1 => 10.5MHz

2 => 5.25MHz

3 => 2.63MHz

4 => 1.32MHz

5 => 0.656MHz

6 => 0.328MHz

7 => 0.164MHz

6 Turn the target power off and turn it back on. Repeat the steps 3 through 5.

Problems with the LAN Interface

If LAN communication does not work

If you cannot verify connection using the procedure in "To verify LAN communication", or if the commands are not accepted by the emulation module:

- Make sure that you wait for the power-on self test to complete before connecting.
- Make sure that the LAN cable is connected. Watch the LAN LED's on the back of the logic analysis system to see whether the system is seeing LAN activity. Refer to your LAN documentation for testing connectivity.
- Check that the host computer or debugger was configured with the correct LAN address. If the logic analysis system is on a different subnet than the host computer, check that the gateway address is correct.
- Make sure that the logic analysis system's IP address is set up correctly.

If it takes a long time to connect to the network

- Check the subnet masks on the other LAN devices connected to your network. All of the devices should be configured to use the same subnet mask.

Subnet mask error messages do not indicate a major problem. You can continue using the emulation module.

The subnet mask is set in the logic analysis system's System Admin window. If it then detects other subnet masks, it will generate error messages.

If there are many subnet masks in use on the local subnet, the logic analysis system may take a very long time to connect to the network after it is turned on.

Problems with the Emulation Probe

To run the power up self test

- 1 Unplug the emulation probe, then plug it in.
- 2 Watch the status lights. They should show the following pattern:
 - = LED is off
 - = LED is on
 - * = Not applicable (LED is off or on)

Normal sequence during power up self test

	Pwr/Target LEDs	Meaning
1	○● ○○	Initial power up, system reset
2	○● ○○	XILINX array initialized successfully
3	○● ●○	XILINX array tested successfully
4	●● ○○	BOOT ROM space tested successfully
5	○● ●○	GENERIC ROM space tested successfully
6	●● ○○	DRIVER ROM space tested successfully
7	○● ●○	RESERVED ROM space tested successfully
8	●● ○○	RAM tested successfully
9	○● ●○	LAN internal feedback tested successfully
10	○● ○○	Boundary scan master (BSM) test begun
11	●● ○●	BSM test completed, start system, load drivers, initialize LAN

Chapter 8: Troubleshooting the Emulator
Problems with the Emulation Probe

If the power up self test fails, the RESET LED will flash the number of the test, then stay lit.

If any of the LEDs fail to change, or all of them remain on, there is a system failure.

Following power up, the LEDs will enter one of the following states:

- | | |
|----|--|
| ○● | No target system power, or emulation probe is not connected to the target system, or |
| ○○ | |
| ○● | Target system is in a reset state |
| ○○ | |
| ●● | Only the boot ROM was used; other firmware in the Flash EPROM has been corrupted |
| ●○ | |

Starting a user interface will change the pattern to the one requested by the interface.

If the power up self tests fail, try the following:

- Check and reset the LAN address as shown in the "Connecting to a Host Computer" chapter. LAN powerup failures will occur if the emulation probe does not have a valid Link Level Address and IP Address.
- Disconnect all external connections, including the LAN, serial (RS-232), and BNC Break and Trigger cables, then cycle power.
- To ensure that the firmware is working as it should, reprogram the firmware, then cycle power.

To execute the built-in performance verification test (emulation probe only)

In addition to the powerup tests, there are several additional performance verification (PV) tests available.

Some of these tests can be performed through the logic analysis system. The LAN tests can only be executed through the RS-232 port.

To perform the PV tests through the logic analysis system

- 1 End any Emulation Control Interface sessions.
- 2 Disconnect the 50-pin cable from the emulation probe, and plug the loopback test board into the emulation probe.

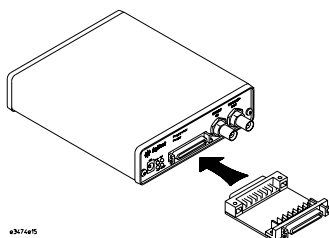

- 3 Connect a BNC cable from the “Break In” connector to the “Trigger Out” connector on the emulation probe.
- 4 From the emulation probe icon menu, open the Performance Verification window.
- 5 Enter the LAN address of the emulation probe.
- 6 Select the number of iterations to perform.
- 7 Click **Start PV**.

The results will appear on screen.

Additional PV Tests

The LAN tests can only be executed through the RS-232 port. The remainder of this section assumes that the tests are being run from a terminal emulator connected to the RS-232 port.

For the BREAK IN, TRIGGER OUT BNC FEEDBACK TEST, connect a coaxial cable between BREAK IN and TRIGGER OUT.

For the TARGET PROBE FEEDBACK TEST, connect the self-test board (Agilent part number E3496-66502).

- 1 Set all of the switches to OPEN.

Chapter 8: Troubleshooting the Emulator
Problems with the Emulation Probe

This is standard RS-232 at 9600 baud which can be connected directly to a 9 pin RS-232 interface that conforms to the IBM PC-AT 9 pin standard.

- 2 Use a terminal emulator to connect to the emulation probe.
- 3 Enter the **pv** command.

Options available for the "pv" are explained in the help screen displayed by typing "help pv" or "? pv" at the prompt.

Examples:

To execute both tests one time:

```
pv 1
```

To execute test 2 with maximum debug output repeatedly until a ^C is entered:

```
pv -t2 -v9 0
```

To execute tests 3, 4, and 5 only for 2 cycles:

```
pv -t3-5 2
```

On a good system, when the feedback connector is plugged into the target connector, the RESET LED will light and the BKG and USER LEDs will be out.

The results on a good system, with the BNC's connected, and with the self-test board plugged in, are as follows:

```
R>pv 1
```

```
Testing: E3499A Series Emulation System
Test # 1: Powerup PV Results           Passed!
Test # 2: LAN 10Base2 Feedback Test    Passed!
Test # 3: LAN 10BaseT Feedback Test    Passed!
Test # 4: Break In and Trigger Out BNC Feedback Test Passed!
Test # 5: Target Probe Feedback Test    Passed!
Test # 6: Boundary Scan Master Test    Passed!
Test # 7: I2C                           Passed!
PASSED  Number of tests: 1              Number of failures: 0
```

Copyright (c) Agilent Technologies 1987

All Rights Reserved. Reproduction, adaptation, or translation without prior written permission is prohibited, except as allowed under copyright laws.

```
E3499A Series Emulation System
Version:  A.05.05 18Nov96 07:47 Proto
Location:  Generics
```

There are some things you can do if a failure is found on one of these tests. Details of Failure can be obtained through using a verbose level of 2 or more.

If the particular failure you see is not listed below, contact Agilent Technologies for assistance.

TEST 2: LAN 10BASE2 Feedback Test failed

For LAN 10BASE2 test, the following is an example of a failure which is *not* caused by a broken emulation probe.

```
R>pv -t2 -v2 1
```

```
Testing: E3499A Series Emulation System
Test # 2: LAN 10Base2 Feedback Test          failed!
FAILED - no lan connection (LAN probably not terminated)
FAILED Number of tests: 1          Number of failures: 1
```

Check to see that the port under test has a good cable connected to it and that the cable is properly terminated with a 50 ohm terminator on each end of the overall cable.

```
R>pv -t2 -v2 1
```

```
Testing: E3499A Series Emulation System
Test # 2: LAN 10Base2 Feedback Test          failed!
FAILED due to excessive collisions
FAILED Number of tests: 1          Number of failures: 1
```

The most common cause of this problem is poor termination of the cable or failure to remove the port under test from the LAN before performing the test. Check to see that the terminators are good (50 Ohms) and that you are isolated from any traffic on a system LAN.

```
R>pv -t2 -v2 1
```

```
Testing: E3499A Series Emulation System
Test # 2: LAN 10Base2 Feedback Test          failed!
FAILED - invalid Ethernet address in EEPROM
FAILED Number of tests: 1          Number of failures: 1
```

First check to see that a correct LLA and IP address have been set in the virtual EEPROM through the "lan" command. If the "lan" command shows bad information for the LLA and IP, then try to set them to correct values. If you are unable to set them to correct values, there is a failure in the FLASH ROM which requires service from Agilent Technologies.

Test 3: 10BaseT Feedback Test failed

```
R>pv -t3 -v2 1
```

```
Testing: E3499A Series Emulation System
Test # 3: LAN 10BaseT Feedback Test          passed!
PASSED  Number of tests: 1          Number of failures: 0
```

In addition to the internal checks performed in Test 2, this test also checks for shorts on the cable connected to the network. If this test fails, disconnect the cable and run the test again. If it then passes, the cable is faulty. If it still fails, it requires service from Agilent Technologies.

If the emulation probe passes this "pv" test, additional testing can be performed through exercising the connection to the network. To run this test, set configuration switch 1 and switch 5 to OPEN, all other configuration switches CLOSED (this enables LAN using 10BaseT). Cycle power and wait for 15 to 30 seconds. Then "ping" the emulaiton probe from your host computer or PC. See the LAN documentation for your host computer for the location and action of the "ping" utility. If the emulaiton probe fails to respond to the "ping" request, verify that the lan parameters (IP address and gateway address) are set correctly and that your host computer recognizes the IP address of the emulation probe. If all else is good, then failure to respond to ping indicates a faulty emulation probe.

E3499A TEST 4: Break In and Trigger Out BNC Feedback Test

```
R>pv -t4 -v2 1
```

```
Testing: E3499A Series Emulation System
Test # 4: Break In and Trigger Out BNC Feedback Test    failed!
Break In not receiving Break Out HIGH
FAILED  Number of tests: 1          Number of failures: 1
```

Before returning to Agilent Technologies, check to ensure that you have connected a good Coaxial cable between the two BNCs. If the cable is good, the emulation probe is bad.

TEST 5: Target Probe Feedback Test

A verbose output on this test can be extensive. For example, the following is the output of this test if you forget to plug in the self-test board.

```
p>pv -t5 -v2 1
```

```
Testing: E3499A Series Emulation System
Test # 5: Target Probe Feedback Test                                failed!
  Bad 20 Pin Status Read when unconnected = 0x7fb7
                                Expected Value = 0xffb7
  Bad 20 Pin Status Read when connected= 7fb7
                                Expected Value = 0x7fb7
  Output 19 Low not received on Input 11
  Output 11 Low not received on Input 19
  Output 13 Low not received on Input 1
  Output 12 High not received on Input 6
  Output 12 and Input 6 not pulled high on release
  Output 8 Low not received on Input 10
  Output 7 Low not received on Input 20
  Output 4 Low not received on Input 14
  Output 2 Low not received on Input 18
FAILED Number of tests: 1          Number of failures: 1
```

If the you get a verbose output like this, check to make sure that the self test board was connected properly.

Problems with the Emulation Module

Occasionally you may suspect a hardware problem with the emulation module or target interface module. The procedures in this section describe how to test the hardware, and if a problem is found, how to repair or replace the broken component.

To run the built-in performance verification test using the logic analysis system (emulation module only)

- 1 End any Emulation Control Interface or debugger sessions.
- 2 Disconnect the 50-pin cable from the emulation module, and plug the loopback test board (Agilent part number E3496-66502) into the emulation module.

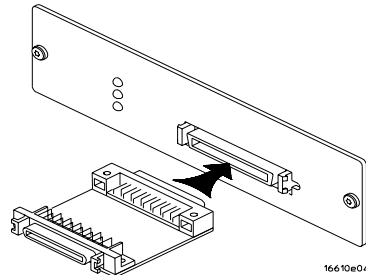

- 3 In the system window, click the emulation module and select **Performance Verification**.
- 4 Click **Start PV**.
The results will appear on screen.

To run complete performance verification tests using a telnet connection

- 1 Disconnect the 50-pin cable from the emulation module, and plug the loopback test board (Agilent part number E3496-66502) directly into the emulation module. Do not plug anything into the other end of the loopback test board.

On a good system, the RESET LED will light and the BKG and USER LEDs will be out.

- 2 telnet to the emulation module.
- 3 Enter the **pv 1** command.

See Also

Options available for the "pv" command are explained in the help screen displayed by typing "help pv" or "? pv" at the prompt. Note, however, that some of the options listed may not apply to your emulation module.

Examples:

If you are using a UNIX system, to telnet to a logic analysis system named "mylogic", enter:

```
telnet mylogic 6472
```

Here are some examples of ways to use the **pv** command.

To execute both tests one time:

```
pv 1
```

To execute test 2 with maximum debug output repeatedly until a ^C is entered:

```
pv -t2 -v9 0
```

To execute tests 3, 4, and 5 only for 2 cycles:

```
pv -t3-5 2
```

The results on a good system with the loopback test board connected, are as follows:

```
M>pv 1
```

```
Testing: E3499C Series Emulation System
Test  1: Powerup PV Results                Passed!
Test  2: Target Probe Feedback Test        Passed!
Test  3: Boundary Scan Master Test         Passed!
Test  4: I2C Test                          Passed!
Test  5: Data Lines Test                   Passed!
PASSED  Number of tests: 1                Number of failures: 0
```

Copyright (c) Agilent Technologies 1987
All Rights Reserved. Reproduction, adaptation, or translation without prior
written permission is prohibited, except as allowed under copyright laws.

Chapter 8: Troubleshooting the Emulator
Problems with the Emulation Module

E3499C Series Emulation System
Version: A.07.51 17Dec97
Location: Generics

E3469A Hitachi SH7709A/29 Emulator
Version: A.01.00

M>

Problem with the TIM

To perform the TIM only PV tests with an emulation probe/module

- 1 End any Emulation Control Interface or debugger sessions.
- 2 Plug the 30-pin cable to the loop-back connector of the TIM.

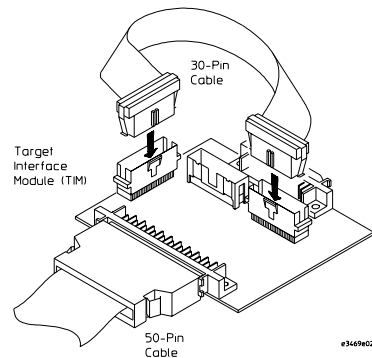

- 3 Telnet to the emulation probe/module.
- 4 Enter **pv 1** command.

The result will appear on screen as below.

```
Testing: E3499B Series Emulation System
  Test 1: Powerup PV Results                Passed!
  Test 2: LAN 10Base2 Feedback Test         Not Executed!
  Test 3: LAN 10BaseT Feedback Test         Not Executed!
  Test 4: Break In and Trigger Out BNC Feedback Test Passed!
  Test 5: Target Probe Feedback Test        Not Executed!
  Test 6: Boundary Scan Master Test         Not Executed!
  Test 7: I2C Test                          Not Executed!
  Test 8: Data Lines Test                   Passed!
Testing: E3469A Hitachi SH7709A/29 Series Emulator
  Test 1: TIM Test                          Passed!
PASSED Number of tests: 1                   Number of failures: 0
```

Copyright (c) Agilent Technologies 1987
All Rights Reserved. Reproduction, adaptation, or translation without prior written permission is prohibited, except as allowed under copyright laws.

Chapter 8: Troubleshooting the Emulator
Problem with the TIM

E3499B Series Emulation System
Version: A.07.07 06Jul98 12:56
Location: Generics

E3469A Hitachi SH7709A/29 Emulator
Version: A.01.00

Details of the failure can be obtained through using a -v option ("verbose" level) of 2 or more.

- Check that the loopback test board is connected.
- If the problem persists, contact Agilent Technologies for assistance.

Returning Parts to Agilent Technologies for Service

The repair strategy for this emulation solution is board replacement.

Exchange assemblies are available when a repairable assembly is returned to Agilent Technologies. These assemblies have been set up on the "Exchange Assembly" program. This lets you exchange a faulty assembly with one that has been repaired, calibrated, and performance verified by the factory. The cost is significantly less than that of a new assembly.

To return a part to Agilent Technologies

- 1 Follow the procedures in this chapter to make sure that the problem is caused by a hardware failure, not by configuration or cabling problems.
- 2 In the U.S., call 1-800-403-0801. Outside the U.S., call your nearest Agilent Technologies sales office. Ask them for the address of the nearest Agilent Technologies service center.
- 3 Package the part and send it to the Agilent Technologies service center.
Keep any parts which you know are working. For example, if only the target interface module is broken, keep the emulation module and cables.
- 4 When the part has been replaced, it will be sent back to you.
The unit returned to you will have the same serial number as the unit you sent to Agilent Technologies.

The Agilent Technologies service center can also troubleshoot the hardware and replace the failed part. To do this, send your entire measurement system to the service center, including the logic analysis system, target interface module, and cables.

In some parts of the world, on-site repair service is available. Ask an Agilent Technologies sales or service representative for details.

To obtain replacement parts

The following table lists some parts that may be replaced if they are damaged or lost. The part numbers are subject to change. Contact your nearest Agilent Technologies Sales Office for further information.

Part numbers

Exchange Assemblies

Part Number	Description
16600-66515	Emulation module
E3469-66401	Programmed emulation probe assembly
E3469-60001	Target Interface Module

Replacement Assemblies

Part Number	Description
E3467-61601	14-pin target cable
E3469-61601	30-pin target cable
E3469-61602	36-pin target cable
E3496-61601	50-pin control cable
E3496-66502	Loopback test board
16700-61608	Expansion cable for emulation module
0950-3043	Power supply for emulation probe

Cleaning the Instrument

If the instrument requires cleaning:

- 1 Remove power from the instrument.
- 2 Clean the instrument with a mild detergent and water.
- 3 Make sure that the instrument is completely dry before reconnecting it to a power source.

Chapter 8: Troubleshooting the Emulator
Cleaning the Instrument

Glossary

Analysis Probe

A probing solution connected to the target microprocessor. It provides an interface between the signals of the target microprocessor and the inputs of the logic analyzer. Formerly called a "preprocessor."

Elastomeric Probe Adapter

A connector that is fastened on top of a target microprocessor using a retainer and knurled nut. The conductive elastomer on the bottom of the probe adapter makes contact with pins of the target microprocessor and delivers their signals to connection points on top of the probe adapter.

Emulation Module

An emulation module is installed within the mainframe of a logic analyzer. It provides run control within an emulation and analysis test setup. See Emulation Probe.

Emulation Probe

An emulation probe is a standalone instrument connected to the mainframe of a logic analyzer. It provides run control within an emulation and analysis test setup. Formerly called a

"processor probe" or "software probe." See Emulation Module.

Extender

A part whose only function is to provide connections from one location to another. One or more extenders might be stacked to raise a probe above a target microprocessor to avoid mechanical contact with other components installed close to the target microprocessor. Sometimes called a "connector board."

Flexible Adapter

Two connection devices coupled with a flexible cable. Used for connecting probing hardware on the target microprocessor to the analysis probe.

General-Purpose Flexible Adapter

A cable assembly that connects the signals from an elastomeric probe adapter to an analysis probe. Normally, a male-to-male header or transition board makes the connections from the general-purpose flexible adapter to the analysis probe.

High-Density Adapter Cable

A cable assembly that delivers signals from an analysis probe hardware

Glossary

interface to the logic analyzer pod cables. A high-density adapter cable has a single Mictor connector that is installed into the analysis probe, and two cables that are connected to corresponding odd and even logic analyzer pod cables.

High-Density Termination Adapter Cable

Same as a High-Density Adapter Cable, except it has a termination in the Mictor connector.

Jumper

Moveable direct electrical connection between two points.

Mainframe Logic Analyzer

A logic analyzer that resides on one or more board assemblies installed in an Agilent Technologies 16500, 1660x, or 16600A/700A-series mainframe.

Male-to-male Header

A board assembly that makes point-to-point connections between the female pins of a flexible adapter or transition board and the female pins of an analysis probe.

Preprocessor

See Analysis Probe.

Preprocessor Interface

See Analysis Probe.

Probe adapter

See Elastomeric Probe Adapter.

Processor Probe

See Emulation Probe.

Prototype Analyzer

The Agilent Technologies 16505A prototype analyzer acts as an analysis and display processor for the Agilent Technologies 16500B/C logic analysis system. It provides a windowed interface and powerful analysis capabilities. Replaced by Agilent Technologies 16600A/700A-series logic analysis systems.

Run Control Probe

See Emulation Probe and Emulation Module.

Setup Assistant

A software program that guides a user through the process of connecting and configuring a logic analyzer to make measurements on a specific microprocessor.

Shunt Connector.

See Jumper.

Software Probe

See Emulation Probe.

Solution

Agilent Technologies' term for a set of tools for debugging your target system. A solution includes probing, inverse assembly, the Agilent Technologies B4620B Source Correlation Tool Set, and possibly an emulation module.

Stand-alone Logic Analyzer

A standalone logic analyzer has a predefined set of hardware components which provide a specific set of capabilities. It is designed to perform logic analysis. A standalone logic analyzer differs from a mainframe logic analyzer in that it does not offer card slots for installation of additional capabilities, and its specifications are not modified based upon selection from a set of optional hardware boards that might be installed within its frame.

Target Control Port

An 8-bit, TTL port on a logic analysis system that you can use to send signals to your target system. It does not function like a pattern generator or emulation module, but more like a remote control for the target's switches.

Target Interface Module

A small circuit board which connects the 50-pin cable from an emulation module or emulation probe to signals from the debug port on a target system.

TIM

See Target Interface Module.

Trigger Specification

A set of conditions that must be true before the instrument triggers. See the printed or online documentation for your logic analyzer for details.

Transition Board

A board assembly that obtains sig-

nals connected to one side and rearranges them in a different order for delivery at the other side of the board.

1/4-Flexible Adapter

An adapter that obtains one-quarter of the signals from an elastomeric probe adapter (one side of a target microprocessor) and makes them available for probing.

Glossary

Index

A

address, IP
 See IP address
altitude specifications, 77
analysis probe
 connecting to, 63
 definition, 115
 equipment required, 16
 equipment supplied, 14
 overview, 2
 processors supported, 4
 product numbers, 4

B

BDM port
 See debug port
BKG light, 102, 107
BNC
 LAN, 27
BNC, LAN, 75
BOOTP, 32
built-in commands
 LAN configuration, 29
 list of commands, 85–87

C

cable
 LAN, 34
 power, 18
 serial, 37
cables
 emulator, 62
 replacing, 112
CD-ROM, installing software from, 50
checklist, setup, 13
cleaning, 113
clocks
 specifications, 75
configuration
 flowchart, 13
configuration files
 installing, 47, 49–50
connection
 emulation module, 41–42, 51–52
 host workstation, 25–39
 problems, LAN, 89, 97
 problems, RS-232, 91
connector

 10BASE2, 27–35, 75
 10BASE-T, 27–35, 75
 serial, 75
connector board, 115

D

data communications
 specifications, 75
DCE or DTE selection and RS-232
cable, 91
debug port
 connecting to, 62
debuggers
 writing, 86
development port
 See debug port
directories
 software installation, 50
driver firmware error, 95

E

elastomeric probe adapter
 definition, 115
emulation module
 16600 installation, 45
 16700A installation, 43
 connecting, 42–46, 52, 61–63
 definition, 115
 description of, 3
 product numbers, 4
 target system design, 56–??
emulation probe
 definition, 115
emulation solution
 See solution
equipment required
 emulation migration, 22
 emulation module, 20
equipment supplied
 analysis probe, 14
 emulation migration, 21–22
 emulation module, 19–20
 ordering information, 4
 overview, 4
ethernet address, 29
extender, 115

F

firmware, updating, 68
flash EPROM, 68
flexible adapter
 definition, 115
flowchart, setup, 13
full solution, 3

G

gateway address, 30, 89
general-purpose flexible adapter
 definition, 115

H

high-density adapter cable
 definition, 115
high-density termination adapter cable
 definition, 116
host computer
 connecting to, 25–39

I

IEEE 802.3, 27–35
information sources, 23
init command, 95
installation, software, 47, 49–50
internet address
 See IP address
IP address, 27–29, 88–89

J

jumper, definition, 116

L

LAN
 problems, 97–98
lan command, 29
LAN connection problems, 89, 103–104
LAN interface, 27–35
LAN parameters, configuring
 BOOTP, 32
 methods, 27
 terminal interface, 29
lights
 See status lights
link beat, 34
link level address, 29, 32

Index

-
- LINK light, 83
loading configurations, vs. installing, 47, 49–50
- M**
mainframe logic analyzer
 definition, 116
male-to-male header
 definition, 116
mask, subnet, 90, 98
MAU, 27, 75
microprocessors supported, 4
- P**
PC
 connecting to, 25–39
performance verification test, 101, 106
ping command, 89
POL light, 83, 90
port number, 30
port number, emulation module, 85
power cord, 16–18
power failure during firmware update, 69
power on/off sequence, 18
power up self test, 99
preprocessor
 See analysis probe
prgflash, 68
probe, testing, 105
problems
 emulation module, 79–113
processor support package, 50
processors supported, 4
product numbers, 4
prompts, 86
 list of, 86
 troubleshooting, 95
prototype analyzer
 definition, 116
- PV
 See performance verification test
- R**
references, 23
register commands, 93
repair
 emulation module, 111–113
 requirements
 target system, 56–??
RESET
 light, 82
 signal, 56
RESET light, 83
RS-232
 See serial connection
run control tool
 See emulation control interface
- S**
self test, 99
serial connection
 DCE or DTE selection, 91
 number of connections, 91
 problems, 91
 setting up, 36–39
 verifying, 39
service ports, TCP, 30
service, how to obtain, 111
setup assistant
 definition, 116
setup checklist, 13
slow clock, 81
software
 installing, 47
 list of installed, 49
software probe
 See emulation module
 See emulation probe
solution
 at a glance, 2
 definition, 116
solutions
 description of, 2
 product numbers, 4
specifications
 altitude, 77
 clock, 75
 data communications, 75
 temperature, 77
 trigger in/out, 75
StarLAN, 27, 34
status lights, 82–84, 99
subnet mask, 27, 89–90, 98
switches
 bootp, 33
 LAN configuration, 29, 34
 serial configuration, 37
- T**
target control port, 117
target interface module (TIM)
 connecting, 62
 definition, 117
target system
 connecting to, 42–46, 52
 problems with, 93–??
 requirements for emulation, 56–??
telnet, 35, 85, 88
temperature specifications, 77
terminal (MS Windows program), 91
terminal interface, 35
 LAN parameters, setting, 29
 See also built-in commands
tests, emulation module, 106–??
ThinLAN, 27, 75
transition board
 definition, 117
trigger
 in/out specifications, 75
troubleshooting, 81
 emulation module, 79–113
turning on power, 18
TX light, 83
- U**
update, firmware, 68
USER light, 82–83
- W**
web sites
 logic analyzers, 23
workstation
 connecting to, 25–39
-

DECLARATION OF CONFORMITY

according to ISO/IEC Guide 22 and EN 45014

Manufacturer's Name: Agilent Technologies
Manufacturer's Address: Digital Design Product Generation Unit
1900 Garden of the Gods Road
Colorado Springs, CO 80907 USA

declares, that the product

Product Name: Emulation Probe
Model Number(s): Agilent Technologies E3469A
Product Option(s): This declaration covers all options of the above product.

conforms to the following Product Specifications:

Safety: EN 61010-1:1993 / IEC 1010-1:1990+A1
EMC: EN 55011:1991 / CISPR 11:1990 - Group 1 Class A ¹⁾
EN 61000-3-2:1995 / IEC 1000-3-2:1995
EN 61000-3-3:1995 / IEC 1000-3-3:1994
EN 50082-1:1992
IEC 801-2:1991 - 4 kV CD, 8 kV AD
IEC 801-3:1984 - 3 V/m, 1 kHz 80% AM, 27 MHz - 1 GHz
IEC 801-4:1988 - 0.5 kV Signal Lines, 1 kV Power Lines

Supplementary Information:

The product herewith complies with the requirements of the EMC Directive 89/336/EEC and the Low Voltage Directive 73/23/EEC and carries the CE marking accordingly.

¹⁾ The product was tested in a typical configuration.

Colorado Springs, 09/16/99

Ken Wyatt / Product Regulations Manager

©Copyright Agilent Technologies 1994-2000

All Rights Reserved. Reproduction, adaptation, or translation without prior written permission is prohibited, except as allowed under the copyright laws.

Restricted Rights Legend

Use, duplication, or disclosure by the U.S. Government is subject to restrictions set forth in subparagraph (C) (1) (ii) of the Rights in Technical Data and Computer Software Clause in DFARS 252.227-7013.

Agilent Technologies, 3000 Hanover Street, Palo Alto, CA 94304 U.S.A.

Rights for non-DOD U.S. Government Departments and Agencies are set forth in FAR 52.227-19(c)(1,2).

Document Warranty

The information contained in this document is subject to change without notice.

Agilent Technologies makes no warranty of any kind with regard to this material, including, but not limited to, the implied warranties of merchantability or fitness for a particular purpose.

Agilent Technologies shall not be liable for errors contained herein or for damages in connection with the furnishing, performance, or use of this material.

Safety

• This apparatus has been designed and tested in accordance with IEC Publication 1010, Safety Requirements for Measuring Apparatus, and has been supplied in a safe condition. This is a Safety Class I instrument (provided with terminal for protective earthing). Before applying power, verify that the correct safety precautions are taken (see the following warnings). In addition, note the external markings on the instrument that are described under "Safety Symbols."

Warning

- Before turning on the instrument, you must connect the protective earth terminal of the instrument to the protective conductor of the (mains) power cord. The mains plug shall only be inserted in a socket outlet provided with a protective earth contact. You must not negate the protective action by using an extension cord (power cable) without a protective conductor (grounding). Grounding one conductor of a two-conductor outlet is not sufficient protection.
- Only fuses with the required rated current, voltage, and specified type (normal blow, time delay, etc.) should be used. Do not use repaired fuses or short-circuited fuseholders. To do so could cause a shock or fire hazard.

- Service instructions are for trained service personnel. To avoid dangerous electric shock, do not perform any service unless qualified to do so. Do not attempt internal service or adjustment unless another person, capable of rendering first aid and resuscitation, is present.
- If you energize this instrument by an auto transformer (for voltage reduction), make sure the common terminal is connected to the earth terminal of the power source.
- Whenever it is likely that the ground protection is impaired, you must make the instrument inoperative and secure it against any unintended operation.
- Do not operate the instrument in the presence of flammable gasses or fumes. Operation of any electrical instrument in such an environment constitutes a definite safety hazard.
- Do not install substitute parts or perform any unauthorized modification to the instrument.
- Capacitors inside the instrument may retain a charge even if the instrument is disconnected from its source of supply.
- Use caution when exposing or handling the CRT. Handling or replacing the CRT shall be done only by qualified maintenance personnel.

Safety Symbols



Instruction manual symbol: the product is marked with this symbol when it is necessary for you to refer to the instruction manual in order to protect against damage to the product.



Hazardous voltage symbol.



Earth terminal symbol: Used to indicate a circuit common connected to grounded chassis.

WARNING

The Warning sign denotes a hazard. It calls attention to a procedure, practice, or the like, which, if not correctly performed or adhered to, could result in personal injury. Do not proceed beyond a Warning sign until the indicated conditions are fully understood and met.

CAUTION

The Caution sign denotes a hazard. It calls attention to an operating procedure, practice, or the like, which, if not correctly performed or adhered to, could result in damage to or destruction of part or all of the product. Do not proceed beyond a Caution symbol until the indicated conditions are fully understood or met.

Agilent Technologies
P.O. Box 2197
1900 Garden of the Gods Road
Colorado Springs, CO 80901

Product Warranty

This Agilent Technologies product has a warranty against defects in material and workmanship for a period of one year from date of shipment. During the warranty period, Agilent Technologies Company will, at its option, either repair or replace products that prove to be defective.

For warranty service or repair, this product must be returned to a service facility designated by Agilent Technologies.

For products returned to Agilent Technologies for warranty service, the Buyer shall prepay shipping charges to Agilent Technologies and Agilent Technologies shall pay shipping charges to return the product to the Buyer. However, the Buyer shall pay all shipping charges, duties, and taxes for products returned to Agilent Technologies from another country.

Agilent Technologies warrants that its software and firmware designated by Agilent Technologies for use with an instrument will execute its programming instructions when properly installed on that instrument. Agilent Technologies does not warrant that the operation of the instrument software, or firmware will be uninterrupted or error free.

Limitation of Warranty

The foregoing warranty shall not apply to defects resulting from improper or inadequate maintenance by the Buyer, Buyer-supplied software or interfacing, unauthorized modification or misuse, operation outside of the environmental specifications for the product, or improper site preparation or maintenance.

No other warranty is expressed or implied. Agilent Technologies specifically disclaims the implied warranties of merchantability or fitness for a particular purpose.

Exclusive Remedies

The remedies provided herein are the buyer's sole and exclusive remedies. Agilent Technologies shall not be liable for any direct, indirect, special, incidental, or consequential damages, whether based on contract, tort, or any other legal theory.

Assistance

Product maintenance agreements and other customer assistance agreements are available for Agilent Technologies products.

For any assistance, contact your nearest Agilent Technologies Sales Office.

Certification

Agilent Technologies certifies that this product met its published specifications at the time of shipment from the factory. Agilent Technologies further certifies that its calibration measurements are traceable to the United States National Institute of Standards and Technology, to the extent allowed by the Institute's calibration facility, and to the calibration facilities of other International Standards Organization members.

About this edition

This is the *Hitachi SH7709A/29 Emulation User's Guide*.

Publication number
E3469-97004, July 2000

Printed in USA.

New editions are complete revisions of the manual. Many product updates do not require manual changes; and, conversely, manual corrections may be done without accompanying product changes. Therefore, do not expect a one-to-one correspondence between product updates and manual updates.

UNIX is a registered trademark of The Open Group.

Windows, MS Windows, Windows NT, and MS-DOS are U.S. registered trademarks of Microsoft Corporation.

X/Open is a registered trademark, and the X device is a trademark of X/Open Company Ltd. in the UK and other countries.